

Diagnostic device of the sewage pumping station

Valeriy Martynyuk^{1*}, Vitaliy Noryk¹, Tomasz Kałaczyński²

¹Khmelnytsky National University, 29016, 11 Institutyska Street, Khmelnytsky, Ukraine

²Bydgoszcz University of Science and Technology, Faculty of Mechanical Engineering, Kaliskiego Street 7, 85-796 Bydgoszcz, Poland

Abstract. The diagnostic device of the sewage pumping station for control and accumulation of analog and discrete data of sensors of the sewage pumping station was developed and implemented. The use of such a device allows to achieve a significant increase in the level of user satisfaction, as well as to reduce the costs of diagnostics, maintenance and operation.

1 Introduction

The sewage pumping station pumps sewage from the main collector to the sewage treatment facilities. The mode of operation of the station is determined by its scheme and place in the general complex of structures of the drainage system. Sewage pumping stations that pump household wastewater are equipped with centrifugal horizontal or vertical pumps. The traditional approach to sewage pump station design incorporates both a so-called wet-well and a dry-well, as shown in Figure 1 [1].

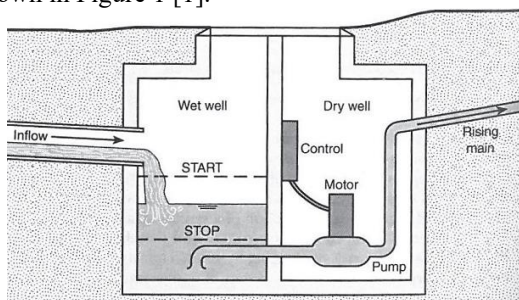

Fig. 1. Sewage Pump Station Design.

Horizontal pumps are used in ground-type pumping stations or stations that have a relatively small depth (3-5 m). At stations with a depth of more than 5 m (mine type), it is more appropriate to use vertical pumps, because in this case the dimensions of the station building in the plan are significantly reduced.

To protect the pumps from clogging, the wastewater is passed through grates or crusher grates installed on the distribution channels near the entrance of the wastewater to the tank. Grates that retain debris can be with manual or mechanized removal of retained debris. Non-mechanized gratings are a set of plates (from staff steel with a section of 10x60 mm) with transparent 16–20 mm, fastened with round (8–10 mm) rods. Grates are installed at an angle of 60–70° to the horizon.

Cleaning of non-mechanized gratings is carried out with a manual rake. Their installation is allowed at small sewerage stations in exceptional cases if the daily volume of garbage removed from the gratings does not exceed 0.1 m³.

In practice, mechanized gratings are most often used, in which the raking mechanism for removing trapped debris is driven by an electric motor through a mechanical gearbox. On the

* Corresponding author: martynyuk.valeriy@gmail.com

general frame of mechanized gratings, which are installed on hinged supports, fixed gratings made of steel plates are fixed in the lower part. In the upper part there is an electric motor and a gearbox with drive chains. The latter rotate the upper guide sprockets, which, in turn, move endless traction chains with rakes attached to them. Depending on the contamination of the wastewater, the number of rakes attached to the chain can be from 1 to 4. The self-cleaning trash rake which circulates outward is shown in Figure 2 [2].



Fig. 2. Self-Cleaning Trash Rake.

For repairs and revisions, mechanical grates on hinged supports can be lifted up. Mechanized gratings of two modifications are produced: vertical and inclined (hereinafter - MHT), which are installed at an angle of 60–80° to the horizon. The width of the transparent grids is taken to be 10–20 mm less than the diameters of the pump cross-sections installed at the sewage pumping station.

The sewage pumping station is a very difficult system that requires the constant equipment diagnostics [3-7]. Diagnostics of the sewage pumping station technical condition is carried out using signals from analog and digital sensors. The diagnostic device for monitoring and accumulating analog and digital parameters of sensors for the sewage pumping station was developed at the Khmelnytskyi National University. The diagnostic device is based on monitoring and accumulating analog and digital parameters of sensors. It is designed for measurement, control, accumulation and visualization of data from analog and digital sensors of pressure and water flow.

2 Diagnostic device for monitoring and accumulating analog and digital parameters of sensors for the sewage pumping station

The diagnostic device consists of the following boards:

- the expansion board for analog sensors - 8 analog inputs in the range from 0 mA to 20 mA;
- the expansion board for digital encoders - 32 digital inputs;
- the control board is a Raspberry Pi single-board computer.

In the device for monitoring and accumulating analog and digital parameters of sensors, it is provided:

- the galvanic isolation of the board of discrete sensors;
- the auto-detection of all involved expansion boards.

In the software of the control device and accumulation of analog and digital parameters of sensors, it is ensured:

- ModBus TCP protocol support (server (slave) mode);
- Web-interface for configuring the device and monitoring sensor readings;
- the system function and the library when accessing any of the scripts written in the programming languages PHP, Perl and Python - a call to the display values of sensors is provided (for each selected analog input of the selected expansion board

- for expansion boards of analog sensors, and for all discrete inputs of the selected expansion board - expansion boards of discrete encoders);
- Ethernet network interface.

The schematic of the expansion board for analog sensors is shown in Figure 3.

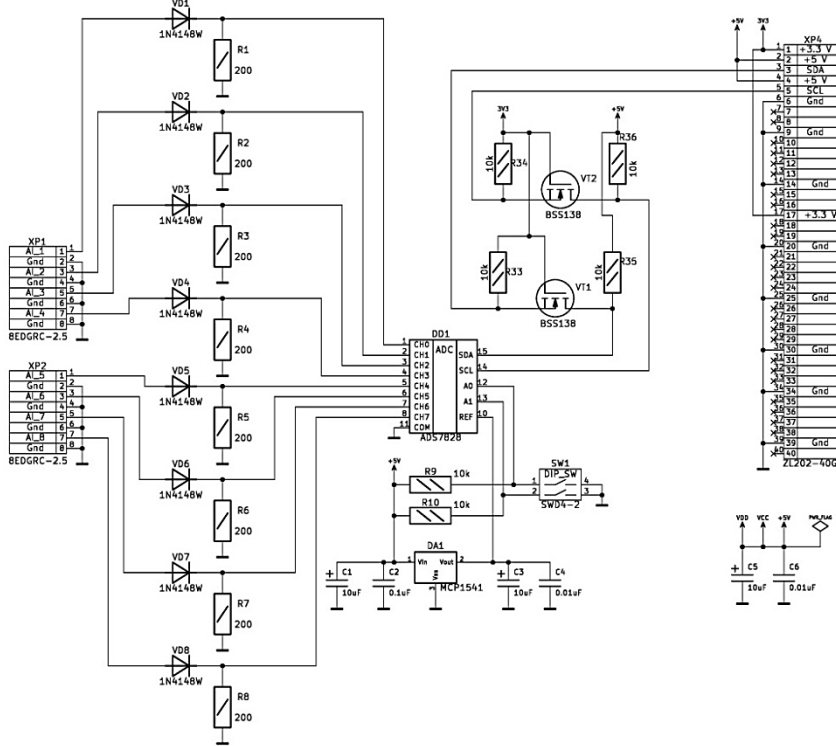

Fig. 3. Schematic of the expansion board for analog sensors.

The ADS7828 ADC is the basis of the expansion circuit board for analog encoders. The ADS7828 ADC is a low-power, single-supply 12-bit data acquisition device that has an I2C serial interface and an 8-channel multiplexer.

The analog-to-digital (A/D) converter has a sample-and-hold amplifier and an internal asynchronous clock. The combination of a serial, 2-wire I2C interface and micro power consumption make the ADS7828 ADC ideal for applications that require the A/D converter to be close to the input signal source in remote locations and for applications that require galvanic isolation.

A low-power, high-precision MCP1541 sample voltage source is used as the ADC reference voltage source. It provides an accurate output voltage of 4.096 V, which is then compared to other voltages in the system.

This reference voltage is typically used in 3V to 5V systems where there can be significant supply voltage fluctuations and the need to minimize power dissipation.

The schematic of the basic expansion board for digital sensors is shown in Figure 4.

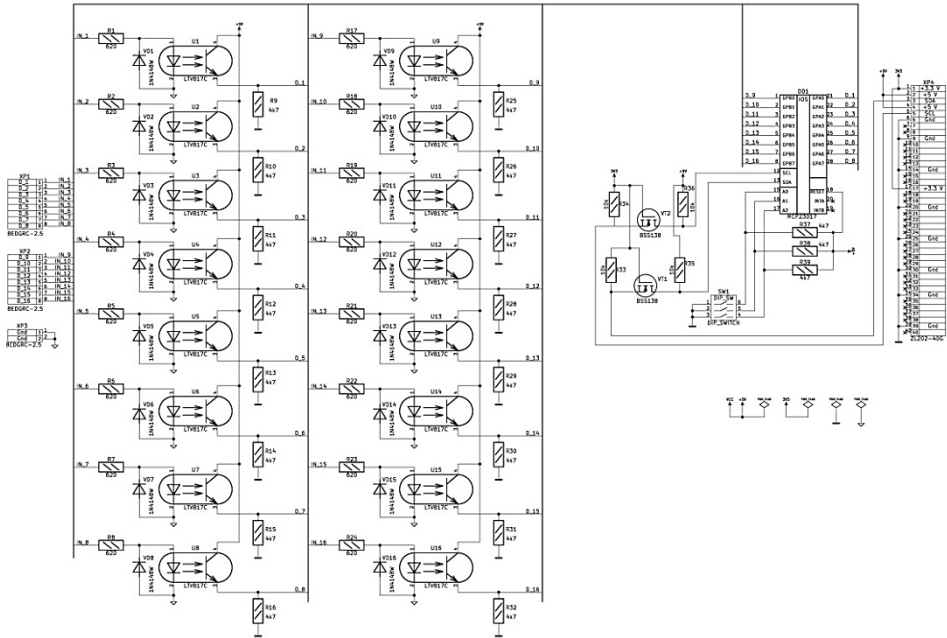

Fig. 4. Schematic of the basic expansion board for digital sensors.

The MCP23017-E/SS port expander is the basis of the expansion circuit board for digital encoders. The MCP23017-E/SS chip allows you to connect up to 16 additional pins to the microcontroller using a two-wire I2C bus for control. Each of these pins can operate in input or output mode.

The MCP23017-E/SS chip has three pins - A0, A1, A2, which are used to set its I2C address, respectively, up to 8 MCP23017 can be connected to one line, getting 128 inputs/outputs.

To ensure galvanic decoupling, we will use an optocoupler PC817. Internally, the optocoupler consists of an LED and a phototransistor, which are not electrically connected in any way, thanks to which, on the basis of PC817, it is possible to implement galvanic isolation of two parts of the circuit.

The third board of the device for monitoring and accumulating analog and digital parameters of sensors is the real-time clock and ModBus interface board. The basis of the real-time clock electrical circuit and ModBus interface is the low-cost, extremely accurate real-time clock (RTC) DS3231.

The DS3231 features an I2C interface with a built-in temperature-compensated crystal oscillator (TCXO) and crystal.

The device has a battery input and maintains accurate time in the event of a power outage. The integration of a crystal resonator increases the long-term accuracy of the device and also reduces the number of parts on the production line.

RTC stores information about seconds, minutes, hours, day, date, month and year. The date at the end of the month is automatically adjusted for months containing less than 31 days, including leap year adjustments. The clock operates in 24-hour or 12-hour format with an AM/PM indicator. Two programmable times of day alarms and a programmable rectangular output are provided. Address and data are transmitted serially over the bidirectional I2C bus.

The schematic of the electrical circuit board for the real-time clock and the ModBus interface is shown in Figure 4.

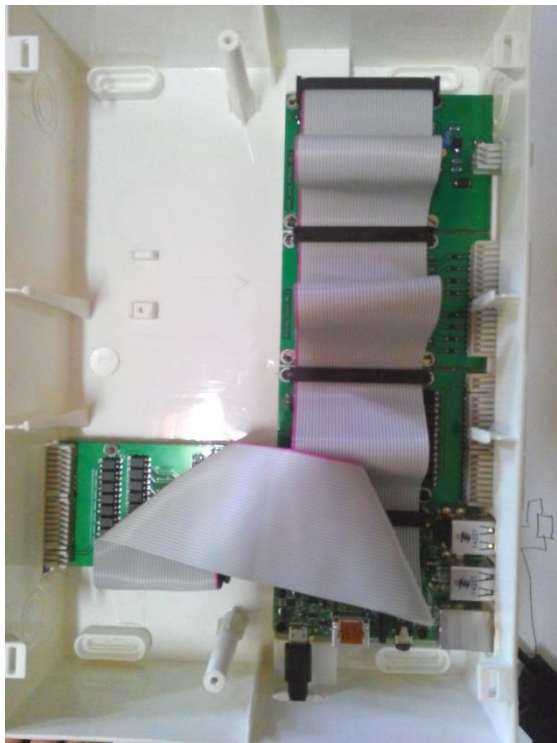

Fig. 6. Internal structure of the diagnostic device for monitoring and accumulating analog and digital parameters of sensors.

The web interface of the diagnostic device for monitoring and accumulating analog and digital parameters of sensors is shown in Figure 7.

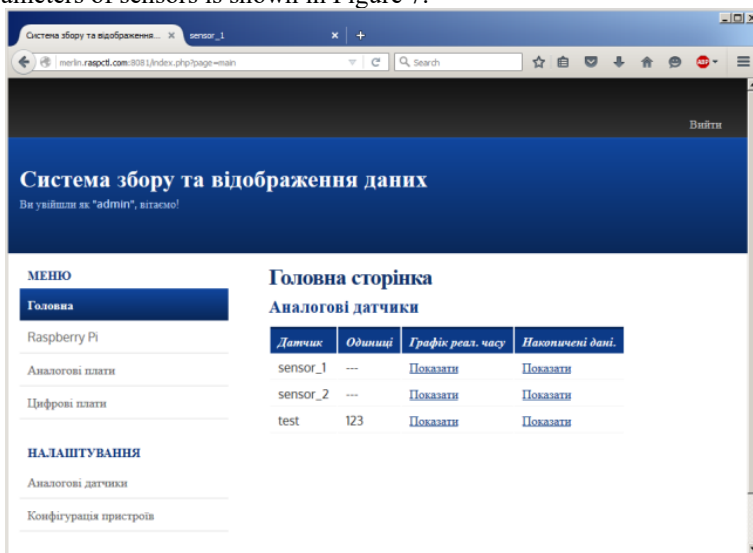

Fig. 7. Web interface of the diagnostic device for monitoring and accumulating analog and digital parameters of sensors.

The web interface of the diagnostic device for monitoring and accumulating analog and digital sensor parameters consists of two parts:

- the user panel;
- the settings panel (available only to the user with the name "admin").

User panel.

The following pages are available to the user:

- the main page of the site ("Home");
- the information about Raspberry Pi ("Raspberry Pi");
- the instantaneous values on all involved analog inputs ("Analog boards", which are shown in Figure 8);
- the value of digital inputs ("Digital boards", which are shown in Figure 9).

Аналогові входи (ModBus input resistors)

30	31	32	33	34	35	36	37
1.878E+3	0.000E+0	0.000E+0	0.000E+0	0.000E+0	1.390E+3	0.000E+0	0.000E+0

Fig. 8. Instantaneous values on all involved analog inputs.

On the main page of the site, the user has the opportunity to open a real-time graph for the selected analog sensor. On the "Analog Boards" page, the instantaneous values of the analog inputs (without taking into account calibration) are displayed to the user.

Дискретні плати (Modbus discrete inputs)

0	1	2	3	4	5	6	7
false	false	false	false	false	false	false	false
8	9	10	11	12	13	14	15
false	false	false	false	false	false	false	false
16	17	18	19	20	21	22	23
false	false	false	false	false	false	false	false
24	25	26	27	28	29	30	31
false	false	false	false	false	false	false	false

Fig. 9. Value of digital inputs.

The headers of the table are filled with the address values of the corresponding input registers of the Modbus protocol. The "Digital Boards" page displays information about the status of discrete inputs. The headers of the table are filled with the address values of the corresponding discrete inputs of the Modbus protocol.

3 Conclusions

Fault diagnosis and fail-safe control of the sewage pumping station is carried out by monitoring and recording data of analog and discrete sensors that measure pressure, flow in pipelines, water levels in tanks and changes in various discrete states of operation of the sewage pumping station.

The proposed diagnostic device for monitoring and accumulating analog and digital parameters of sensors was developed. It was established that the main criteria that should be taken into account when choosing a device for monitoring and accumulating analog and discrete sensor data are the maximum sampling frequency, the number of channels, input ranges, ADC resolution and the possibility of simultaneous collection.

By using of the control devices for accumulation of analog and discrete sensor data allows to achieve a significant increase in the level of user satisfaction, as well as to reduce the costs of maintenance and operation.

References

1. H. Jacobs, M. Griffioen, C. Loubser And J. Tulleken, *Understanding Sewage Pump Stations. Development of a Sewpump Tool*, Report to the Water Research Commission, Stellenbosch University, Institute for Water and Environmental Engineering, (2015)
2. *Mechanical and Electrical Design of Pump Stations*. Manual No. 1110-2-3105, Washington DC, (2020)
3. J. Quevedo, M. Salamero, V. Puig, J. Figueras, G. Cembrano, A. Mart, *Optimal control of urban drainage systems. a case study*, Control Engineering Practice, **12**(1):1–9 (2004)
4. J. Filipe, R., J. Bessa, M. Reis, R. Alves, P. Póvoa, *Data-driven predictive energy optimization in a wastewater pumping station*, Appl. Energy, **252**, 113423 (2019)
5. P. Olszewski, J. Arafteh, *Parametric analysis of pumping station with parallel-configured centrifugal pumps towards self-learning applications*, Appl. Energy, **231**, 1146–1158 (2018)
6. M. Czyżewska, K. Migawa, A. Neubauer, R. Martinod, *Semi-Markov model for the Kaplan preventive repair system for water turbines*, Matec Web of Conferences, **375**, 1-9 (2023)
7. M. Żółtowski, G. Rutkowska, M. Liss, T. Kałaczyński, M. Krejsa, *Vibration Energy Signal Information for Measure Dynamic Preferences of Ceramic Building Materials Using Experimental Modal Analysis Methodology*, Materials, **15**(4), 1452 (2022)