

Shear resistance of prestressed concrete beams with the constant and variable height

Pavel Krivitskiy^{1*}, *Nikifor Matweenko*¹, *Vasilij Malinovskiy*¹ and *Elizabeth Matweenko*¹

¹Brest State Technical University, 224000, Brest, Belarus

Abstract. One of the methods of increasing the efficiency of using prestressed reinforcement involves transferring a certain amount of longitudinal tensioned reinforcement from the tensile zone in the span to the upper compressed zone on the support, where it is not fully used to ensure the bending resistance. More effective may be a solution in which, due to the broken outline along the length of the element, the pre-stressed tendons are arranged at an angle to the longitudinal axis, creating vertical compression of the support zone and increasing the beam shear resistance. In this study presented information about stress-strain state of prestressed concrete straight and curved beams based on the experimental investigations.

1 Introduction

In the conditions of constantly increasing volumes of construction, an important area of research is the search for rational and cost-effective structural solutions of bearing elements of buildings that would have architectural expressiveness and meet aesthetic and psychological requirements.

The use of prestressing in reinforced concrete structures allows, on the one hand, to reduce the size of the elements, which has a beneficial effect not only on the appearance of the building, but also on its architectural and planning solutions. On the other hand, prestressed structures have higher stiffness and crack resistance compared to elements without prestressing [1].

At the same time, prestressed concrete structures also have a number of disadvantages. The main ones include an increase in the complexity of manufacturing structures associated with the need for pre-tensioning of reinforcement and an increase in the cost of the entire structure due to the use of more expensive power forms and high-strength reinforcement.

Throughout the 20th century, researchers from various countries have tried to solve the difficulties of using prestressed structures by using high-strength reinforcement more efficiently or reducing its consumption in the manufacture of the structure. As is known, in single-span beams, the bending moments in the supporting zones of the span are significantly less than in the middle, but the longitudinal reinforcement, selected in the middle of the span, is installed of a constant cross-section along the entire length of the

* Corresponding author: nikifarych@yandex.by

element. At the moment, there are several ways to increase the economic efficiency of prestressed structures.

The first method is the use of mixed reinforcement. This type of reinforcement is acceptable for structures in which the longitudinal reinforcement cross-section is determined by the ultimate limit states, and the calculation according to the serviceability limit states is not limiting. In this case, the value of the prestress can be reduced by replacing a part of the tensioned reinforcement with a non-tensioned one, installed in accordance with the diagram of bending moments in the middle part of the span. Thus, it is possible to obtain a more rational design option - a design of equal resistance.

The second method involves transferring a certain amount of longitudinal tensioned reinforcement from the lower stretched zone in the span to the upper compressed zone on the support, where it is not fully used to ensure the bending resistance.

Designs that combine the advantages of the methods described above can become more effective [2]. The resistance of such elements in the area of maximum bending moments is provided by longitudinal tensioned reinforcement. In the support zone, the entire high-strength reinforcement is bent, which makes it possible to increase the crack resistance of inclined sections and the beam shear resistance. To ensure bending resistance, non-tensioned reinforcement is installed in the support zone.

The use of elements with bent tensioned reinforcement faces certain difficulties associated with the complexity of work on the tension of the reinforcement and the need for devices that ensure the tension of the reinforcement in the bent position or its tightening from the original horizontal position to the design bent.

In the middle of the 20th century, a number of researchers [3, 4, 5, 6] proposed a design solution in which, due to the broken outline along the length of the element, the rectilinear prestressed reinforcement is positioned at an angle to the longitudinal axis, creating vertical compression of the support zone and increasing the beam shear resistance (Figure 1).

Despite the obvious advantages of curved outline structures, they have not found wide application in construction practice, which is due to the lack of reliable experimental and theoretical data on the stress-strain state of the elements of the broken outline, including in the shear zone.

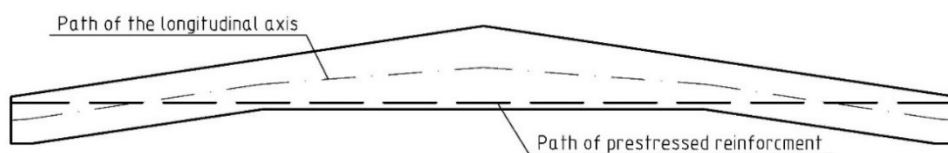
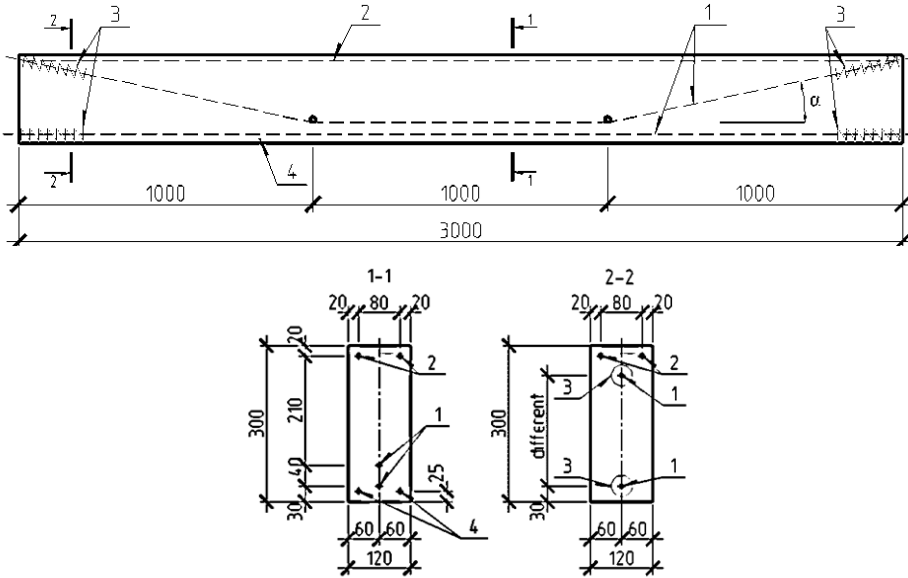

Fig. 1. A beam of a broken outline with a rectilinear tensioned reinforcement

2 Structural solution of beams

In order to identify the features of the operation of the elements of the broken outline, a comparative analysis of the stress-strain state of the shear zone of beams with parallel faces and the bend of a part of the longitudinal prestressed reinforcement (BS series, Figure 2) [7] and gable beams with a broken lower face and rectilinearly positioned reinforcement (BC series, Figure 3) was performed. The structural solution and reinforcement of the beams of the BS series and the BC series are shown in Table 1 and 2, respectively.



1 – tensioned reinforcement, Ø12.5 Y1860S7; 2 – non-tensioned reinforcement of the compressed zone, 2Ø12 S500; 3 – spirals of indirect reinforcement, Ø5 S500; 4 – non-tensioned reinforcement of the middle part of the beam span, 2Ø16 S500

Fig. 2. Structural solution and reinforcement of beams of the BS series

Table 1. Main characteristics of beams of the BS series

Specimen	Sizes, cm			f_{cm} , MPa	Ratio, a/h	α , degrees	The prestressing value of the lower strand, MPa	The prestressing value of the upper strand, MPa
	b	h	l_0					
1	2	3	4	5	6	7	8	9
BS-1	12	30	260	57,7	2,67	9,0	946	928
BS-2	12	30	260	54,2	2,67	9,0	941	920
BS-3	12	30	260	54,1	2,67	9,0	934	915
BS-4	12	30	225	55,8	2,04	9,0	958	921
BS-5	12	30	260	50,3	2,67	12,0	947	930
BS-6	12	30	260	51,9	2,67	9,0	796	780

Table 2. Main characteristics of beams of the BC series

Specimen marking	Dimensions, cm				Shear reinforcement in the middle of the span	f_{cm} , MPa	Tensioned reinforcement	The prestressing value of reinforcement, MPa
	b	h_s	h_i	l				
BC-1	12	35	27	300	Ø6 S240 шаг 150 мм	57.46	Ø12.5 Y1860 S7	502.57
BC-2	12	35	27	300	Ø6 S500 шаг 150 мм	56.55	Ø14 S800	778.09

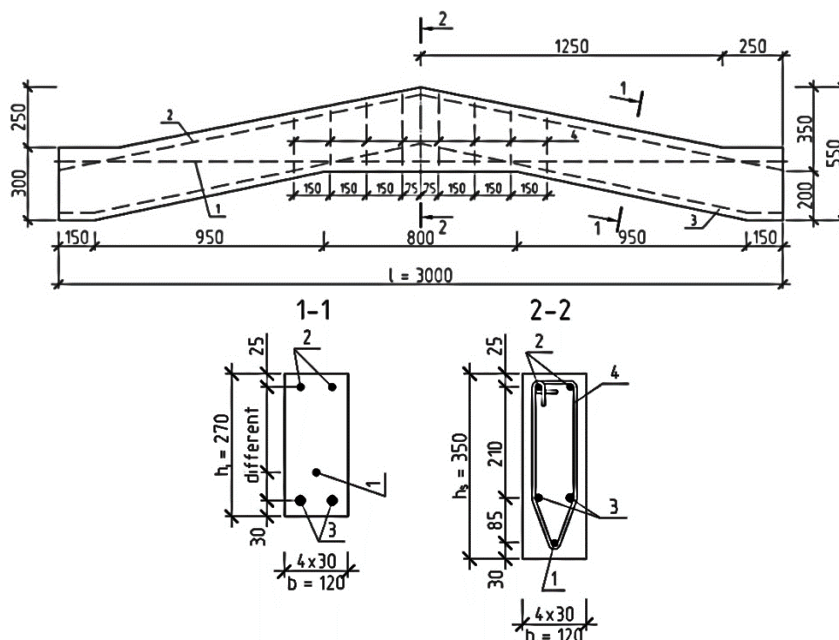

1– tensioned reinforcement, $\text{Ø}12.5$ Y1860S7; 2 – non-tensioned reinforcement of the compressed zone, $2\text{Ø}12$ S500; 3 — non-tensioned reinforcement, $2\text{Ø}16$ S500, 4 – shear reinforcement

Fig. 3. Structural solution and reinforcement of beams of the BC series

Figures 4 and 5 show the value and directions of the main deformations in the shear zone for BC-1 and BS-1 beams at four loading stages: after the end of compression (before the application of external load); before the formation of normal cracks; at the stage corresponding to the work of the beam with normal cracks - before the formation of inclined cracks; at the stage corresponding to the work of the beam with normal and inclined cracks.

3 Stress-strain state of beams of the shear zone

In the beams of the BC series, when concrete is compressed, the vectors of the main compression deformations along the entire length of the inclined part of the beam are oriented horizontally - along the trajectory of the prestressed reinforcement. In this case, the nature of the distribution of the main deformations along the height of the section varies depending on the location of the straining element in the section under consideration. In the vicinity of the fracture of the lower face of the beam, the pre-compression force is applied in the lower part of the section, in connection with which shortening deformations occur in the lower and middle zone of the section, and slight stretching is noted at the top. In the middle of the length of the inclined part, the route of the straining element passes within the core of the section, which leads to the appearance of shortening deformations of approximately equal magnitude along the entire height of the section. In sections located at a distance of up to $1.3d$ from the end of the beam, the trajectory of the stressed reinforcement passes above the upper core point of the section, which leads to the appearance of minor tensile deformations at the lower edge from the action of the compression force.

At the stage before the formation of normal cracks ($4F_{exp} = 40 \text{ kN}$), tensile deformations occur in the lower part of the section, oriented along the lower face. At the same time, along the entire length of the inclined part of the beam, the magnitude of the main extending deformations is within $(17.1...25.2) \times 10^{-5}$. The equal magnitude of longitudinal tensile deformations at the lower face is a sign of the simultaneous formation of normal cracks along the entire length of the structure, which was recorded at the next stage of loading during the experiment.

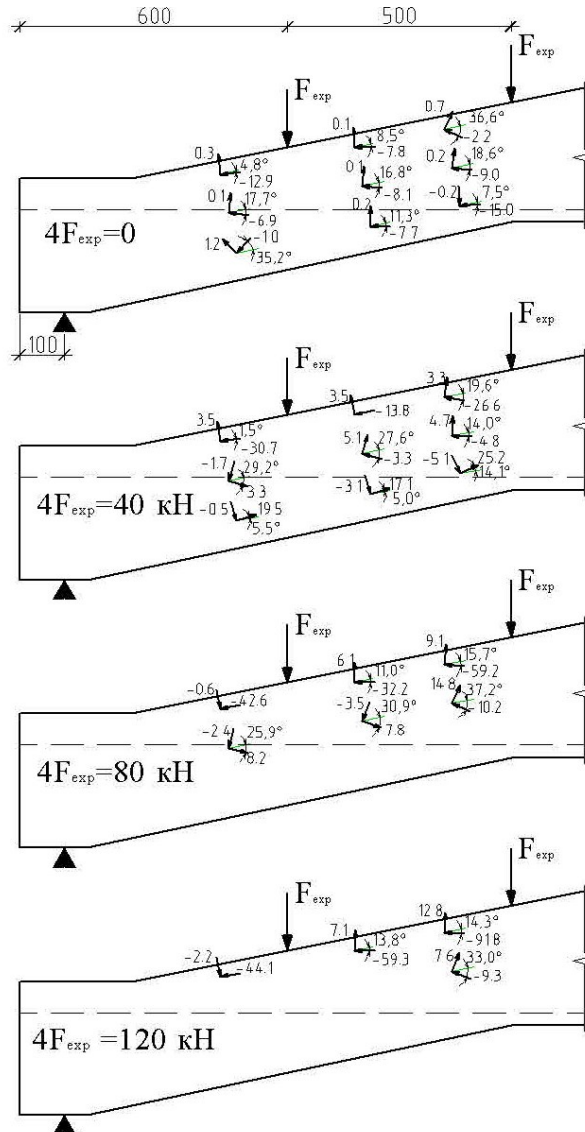

Fig.4 The direction and magnitude of the main deformations ($\epsilon_{1,2} \times 10^{-5}$) in the BC-1 beam from the action of external loading and the pre-compression force

Simultaneously with the increase in tensile strains in the lower part of the section, an increase in the main compressive strains at the upper face oriented along the inclined part of

the beam was noted. At the same time, in the section at the support, the values of compressive strains are greater than in the section at the point of fracture of the lower face, where the bending moment according to the accepted loading scheme is of greater importance. This distribution of the main deformations is the result of the combined action of the external load and the pre-compression force and is due to the design features of the gable beam, namely, the transfer of the longitudinal tensioned reinforcement from the lower section zone in the span to the upper one on the support.

In the middle part of the section, the main compression deformations have an insignificant value, but they acquire a well-defined orientation from the support to the first span load and are directed at an angle of $27.6..29.2^\circ$ to the longitudinal axis.

At the stage after the formation of normal cracks ($4F_{\text{exp}} = 80 \text{ kH}$) in the middle of the section height, the vectors of the main compression deformations retain their orientation from the support to the span load, but acquire a more gentle slope of $25.9..27.2^\circ$.

After the appearance of inclined cracks ($4F_{\text{exp}} = 120 \text{ kH}$), the vectors of compressive deformations in the middle of the cross-section height slightly changed in value and direction, and the vectors of the main extending deformations increased to a greater extent. The angle of inclination of the main deformation sites at the intersection with the route of the straining element was $25..27^\circ$, which subsequently predetermined the angle of inclination of the main inclined crack. The angle of the crack in the beam BC-1 was 36° , in the beam BC-2 – 28° . The more gentle angle of inclination of the diagonal crack in the BC-2 beam is due to the better conditions of adhesion with concrete of the rod tensioned reinforcement in comparison with the rope used in the BC-1 beam.

The destruction of the BC-1 beam occurred along an inclined crack in the support zone and was accompanied by the retraction of the rope at the end of the beam. Due to the reliable anchoring of the strained armature in the BC-2 beam, its shear resistance turned out to be significantly higher and the destruction occurred along normal sections in the middle of the span.

In the BS series, after creating a preliminary compression in the lower zone, the vectors of the main compression deformations are directed horizontally, and in the middle of the cross-section height, the compression vectors are oriented to the point of application of forces in the bent rope. At the same time, the angle of inclination of the main deformations in the beam cut zone is $9,1-10,6^\circ$.

In all beams of the BS series, normal cracks were the first to form in the area between the applied forces. The load level during crack formation was $2F_{\text{exp}} = 60\div 70 \text{ kN}$. At this load, in the middle of the cross-section height in the section area of the beam BO-1, the vectors of the main compressive deformations are slightly inclined to the support. The angle of inclination is 5.4° , and as the load increases, a slight counterclockwise rotation of the main platforms occurs (Figure 5). In the lower part of the section of the BS-1 beam, the vectors of the main tensile deformations in the section whose length is equal to the working height of the section d from the bend of the upper rope are directed at an angle of $9,0-16,7^\circ$, and their values are within $(7,0 - 10,9) \times 10^{-5}$, which is close to the limit (shaded area in Figure 5).

With an increase in the load ($2F_{\text{exp}} = 90\div 100 \text{ kN}$), new normal cracks appeared closer to the support, which were subsequently "transformed" into inclined to the vertical, and their development was slowed down in the inflection zone of the rope, and then above the trace of the bent rope, they moved the trajectory to a more gentle one. In the middle of the section height, the main compression deformations are directed at an angle of $24,3-29,3^\circ$, and the values of the main tensile deformations are $(6,5 - 6,9) \times 10^{-5}$, which is also less than the limit for concrete beams BS-1.

After the appearance of inclined cracks from the lower face ($2F_{exp} = 120 \text{ kN}$), the vectors of the main tensile deformations increased in magnitude. The angle of inclination of the main platforms at the intersection with the rope route was $26.9\div 28.8^\circ$.

As a result, in the support zones, previously and newly formed inclined cracks developed both to the upper and lower faces, forming actual diagonal cracks. The destruction of beams c occurred as a result of crushing of compressed concrete at the end of a critical inclined crack (in beams BS-1÷BS-3) or by cutting concrete of the compressed zone (in beams BS-4÷BS-6). The angle of inclination of critical cracks in the area of intersection with the bent rope was $26\text{-}36^\circ$.

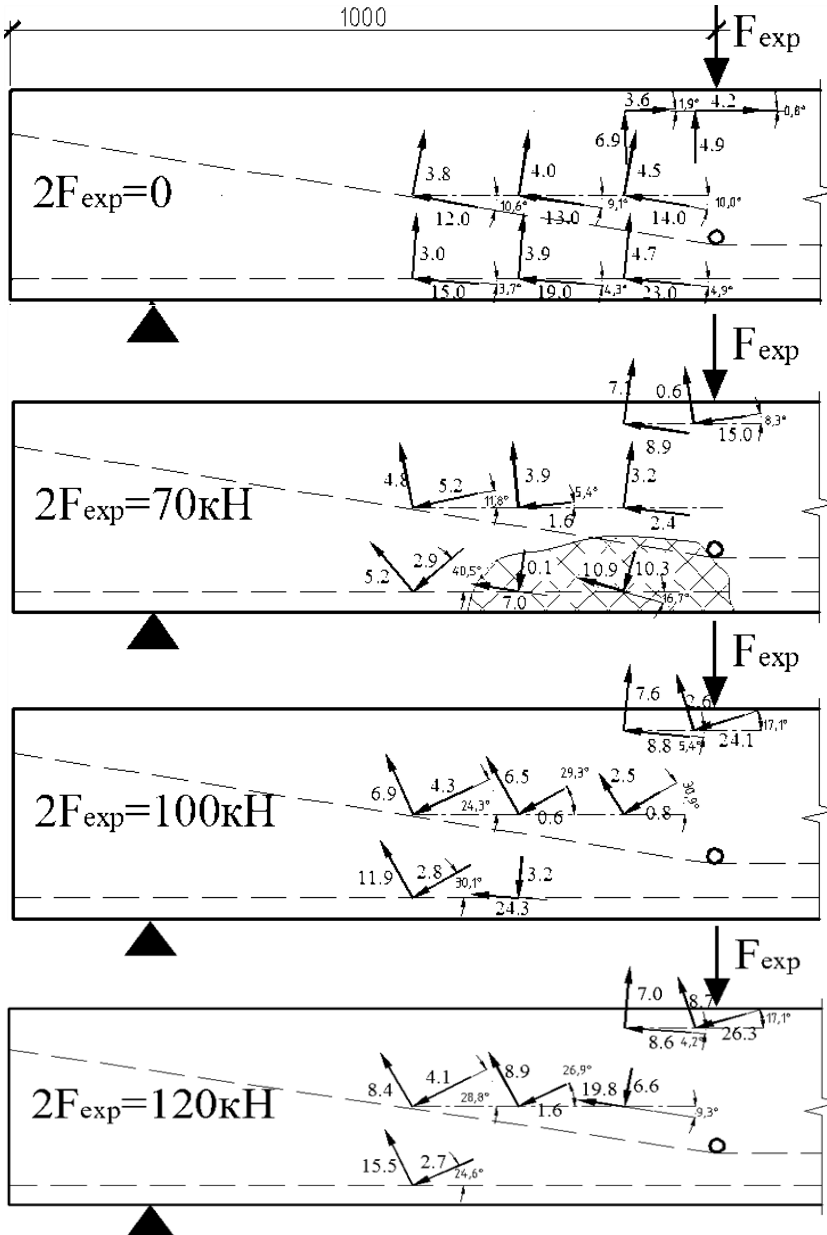

Fig.5. The direction and magnitude of the main deformations ($\varepsilon_{1,2} \times 10^{-5}$) in the BS-1 beam from the action of external loading and the pre-compression force

4 Conclusions

Based on the results of the analysis of the stress-strain state straight and curved beams, the following conclusions can be drawn:

1. In curved beams with a rectilinear tensioned reinforcement, the main tensile deformations at the lower face reach the limit values simultaneously along the entire length of the inclined part of the beam. This indicates equal crack resistance of normal sections along the entire length of the structure.

2. The angle of inclination of the main crack in the beams of the BC series was $28..36^\circ$, and in the beams of the BS series - $26..36^\circ$. Thus, the stress-strain state of the beams of a broken outline in the cut zone fully corresponds to the peculiarities of the work of straight beams with the bending of a part of the longitudinal reinforcement on the support. It should also be noted that the values of the slope angles of diagonal cracks obtained in the beams of the BC and BS series at the moment of destruction are not large (gentle angles), which indicates that the entire section of the cut is included in the resistance.

3. Regardless of the structural solution of the beam, the anchoring of the longitudinal tensioned reinforcement had the greatest influence on the nature of the destruction. In the samples in which the anchoring of the reinforcement (cable or rod) was provided by constructive measures, the angle of inclination of the main crack turned out to be more gentle, and the shear resistance was higher.

References

1. Mikhailov, V.V. (1978). *Predvaritel'no napryazhennye zhelezobetonnye konstruksii (Teoriya, raschet i podbor sechenii)* [Prestressed reinforced concrete structures (Theory, calculation and selection of sections)]. Moscow: Stroizdat. (In Russ.).
2. Malinovskii, V. N., Matveenko N.V. (2016) *Effektivnost' zhelezobetonnykh konstruksii pri smeshannom armirovanii* [Efficiency of reinforced concrete structures with mixed reinforcement]. *Problemy sovremennogo betona i zhelezobetona* [Contemporary Issues of Concrete and Reinforced Concrete], (8), 155-171. (In Russ., abstr. in Engl.). DOI: 10.23746/2016-8-9.
3. Magnel, G. (1968) *Predvaritel'no napryazhennyi zhelezobeton* [Prestressed concrete]. Moscow: Gosstroizdat. (In Russ.).
4. Leonhardt, F (1953) *Continuous Prestressed Concrete Beams*. Journal of ACI, 22 (7), 617-634.
5. Gorozhanskii, Yu. F. (1968) *Preimushchestva zameny staticheskoi skhemy sbornykh zhelezobetonnykh ram dlya odnoetazhnogo promyshlennogo stroitel'stva* [Benefits of replacing the static scheme of precast concrete frames for single-storey industrial building]. *Respublikanskaya nauchno-tehnicheskaya konferentsiya : tez. dokl* [Republican scientific and technical conference: abstracts. report]. 42-47. (In Russ.).
6. Malinovskii, V. N., Krivitskii P. V., Matveenko N.V. (2013) *Uovershenstvovanniy variant konstruktivnogo resheniya zhelezobetonnykh stropil'nykh balok* [Improved version of the constructive decision reinforced concrete beams]. *Vestnik Brestskogo gosudarstvennogo tekhnicheskogo universiteta* [Bulletin of Brest State Technical University], 79 (1), 128-131. (In Russ., abstr. in Engl.).

7. Malinovskii, V. N., Krivitskii P. V. (2016) *Ekspperimental'nye issledovaniya vliyaniya konstruktsionnykh faktorov na soprotivlenie izgibu s poperechnoi siloi prednapryazhennykh zhelezobetonnykh elementov s kanatnoi otognutoi armaturoi* [Experimental Researches of Influence on Resistance to a Flexure with Shear Force of Prestressed Concrete Beams with Bent-up Seven-Wire Strands of Constructional Factors] *Problemy sovremennogo betona i zhelezobetona* [Contemporary Issues of Concrete and Reinforced Concrete], (8), 134-154. (In Russ., abstr. in Engl.). DOI: 10.23746/2016-8-8.