

Theoretical and experimental research on the possibility of saline water evacuation from the sump of Unirea shaft in Slanic mine

Daniel Cosmin Vitan^{1*}, *Sorina Stănilă*¹, *Ionela Cristina Lăpăduși (Maceșeanu)*², and *Bogdan Brănișteanu*²

¹ University of Petrosani, 20 University street, 332006, Petrosani, Romania

² National Institute for Research and Development in Mine Safety and Protection to Explosion - INSEMEX, 32-34 G-ral Vasile Milea Street, Petrosani, Romania

Abstract. The paper approaches the necessity and implementation of a viable solution for constant saline water evacuation, and its transportation to the surface of the mine. A major problem in Slanic Prahova salt mine has been found to be water infiltration. Sump flooding is due to the high humidity condensation of the air circulating along Unirea sump, making a constant air exchange between the underground and the surface, at a temperature of 12-15 degrees. Water infiltration coming from ground water layers are also a factor favouring sump flooding.

1 General considerations

Water infiltration in underground mines is a general and well-known problem, both at national and at international level. This problem is generally solved by digging close to the galleries and mounting water evacuation installations. [1, 2]

In coal mines, where norms are strict from the point of view of electrical installations and mechanical-electrical installations from the inside of the mine, due to explosive gases in the mines, which can be ignited by sparks, pneumatic water evacuation pumps are used.

Considering that Slanic Prahova Salt Mine there is no such atmosphere, we are allowed to design evacuation installations operating with electricity. On the other hand, the installation made up of absorption pipe, evacuation pipe and exhaust pipe to the mine surface, would have to work in corrosive atmosphere, due to saline water of maximum saturation. [3]

* Corresponding author : vitan.daniel.cosmin@gmail.com

2 Considerations regarding the construction and exploitation of the centrifugal pumps intended for the evacuation of underground water

Mine pumps are used in mine constructions to remove water entering the underground mine workings and used to be the most difficult part of the work. Water evacuation is centuries old, and the first machine used in a mine was a pump. Pumps used to remove water led to the first steam driven machines, and thus to the development of modern technology. The first water evacuation pumps and work in mines were driven by a steam machine located on the ground and a rod was used to actuate the pumps in the mine; they were considered a piece of craftsmanship in those times.

In our days centrifugal reciprocating pumps with piston, diaphragm and compressed air pumps are used in mines. The variety of pumps differ depending on the required parameters that need to be met, so that reciprocating mine pumps are of two kinds, namely: reciprocating mine pump with flywheel and reciprocating mine pump without flywheel. [1]

Reciprocating mine pistons without flywheel are the simplest pumps, driven by a motor or by compressed air. The pump can be with one cylinder and with two cylinders. The two cylinder pump is of higher efficiency and it will function in tandem, that is, when piston I will be in the aspiration cycle, piston II will be in the exhaust cycle. Both pistons are connected to a common aspiration pipe, and to a common exhaust pipe. Pumps that are without flywheel work with total air admission, their operation not being economical. These types of pumps without flywheel, even if they are not economical, are used due to their simplicity, light weight a reduced volume. Aspiration/exhaust flow rates are regulated by circuit parts called air valves.

Reciprocating mine pumps with flywheel are the most economical from the point of view of the energy required for their drive. The consumption of these types of pumps is 20% less than the centrifugal pumps that will be presented below. The rotation of the reciprocating pump with flywheel is 140-300 rpm, that is, the flow rate can increase to m^3/min and the pumping height can reach 600-800 m. Modern reciprocating pumps have rapid run and their aspiration valves are controlled. Reciprocating mine pumps, functioning with closed shut-off valve, can deteriorate if they do not have safety valves mounted in the exhaust part.

Diaphragm mine pumps are used in various fields where significant pumping heights are not required. Diaphragm pumps are used in mines where the evacuated water contains mud or useful minerals. Their design allows self regulation of exhaust flow rates, depending on the resistance exerted by the exhaust matter. The aspiration and exhaust chambers can be on the same side or on both sides of the membrane.

As a result of the theoretical conditions imposed and due to exhaust height, approximately 208 m, of which 5 m the sump height and 203 m the shaft height to the surface, we shall use a submersible pump.

Submersible pumps. In order to evacuate water from mine shafts, vertical centrifugal, suspended, submersible, electrical or pneumatic pumps are most frequently used. Considering that the water level in the shaft permanently varies, these pumps are suspended by steel cables with the help of pulleys.

With these suspended vertical pumps with several rotors, water is aspirated by means of an aspiration and suction pump in the inside housing, reaching the first rotor, then in the leading apparatus. From this point water reaches the following rotor, the process being continued depending on the number of rotors through which it passes, finally reaching the upper housing and in the exhaust pipe. [2].

Figure 1 presents the construction of a submersible 5 stage pump.

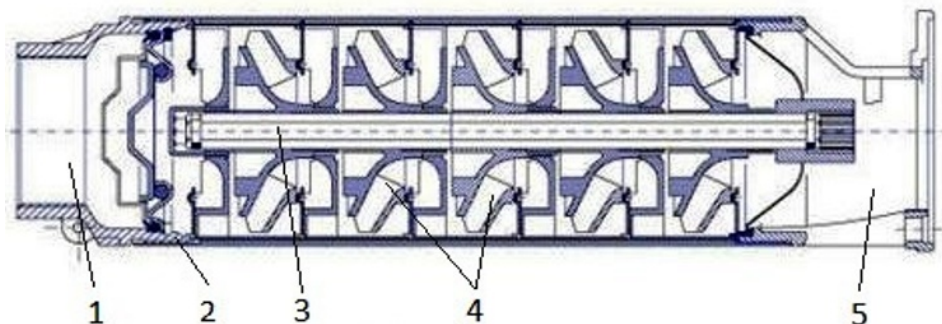

Fig.1. Submersible pump with rotors set out in five stages. 1 – area of pump exhaust, 2 – pump housing, 3 – axis driven by the electric motor, 4 rotors mounted on an axis, 5 – aspiration hole.

Rotors are fixed on a shaft by means of tapered bushings fixed by nuts. The shaft is mounted on rubberized bearings and pressed in the guiding nervures of the pump body.

The shaft is driven by means of a threaded sleeve by the electrical motor with vertical axis I. [3]

The useful driving power of the pump is given by the useful mechanical work in time unit, written in the form:

$$P_u = \frac{\rho g H Q}{1000} \text{ [kW]} \quad (1)$$

where: Q – is the pump flow rate, m³/s.

ρ – liquid density, kg/m³.

H- exhaust height, mH₂O.

From the previous formula (1) flow losses, hydraulic losses or mechanical losses are not considered, therefore the useful power is also called theoretical power.

The power of the electrical motor driving the pump absorbed from the network, is:

$$P_a = \frac{P_u}{\eta} \text{ [kW]} \quad (2)$$

where: η – global performance

$$\eta = \eta_v \cdot \eta_h \cdot \eta_m \quad (3)$$

where: η_v –volumetric performance

η_h – hydraulic performance taking in consideration the pressure losses due to friction between the liquid and the cylinder walls ($\eta_h = 0,8 - 0,9$).

η_m – mechanical performance considering the losses due to various mechanical frictions including transmission losses ($\eta_m = 0,85 - 0,95$).

3 Study of constructive and functional parameters of the evacuation system for Slanic Prahova salt mine

To dimension the water evacuation pump, we should take in consideration the water volume to be evacuated, the height at which the pump would evacuate the water and the height between the pump and the suction of the pump.

The water volume to be evacuated from the sump is determined by the sump dimensions, being the following: L=4 m , l= 3m , h_j= 5 m.

Total volume is given by the formula:

$$V = L \cdot l \cdot h_j = 4 \cdot 3 \cdot 5 = 60 \text{ m}^3 \quad (4)$$

The water volume evacuated, namely 60 m^3 , will be refilled in the sump in approximately one week (that is 168 hours), then re-evacuation follows. In these conditions we shall calculate the necessary criteria of the pump that will be part of the new saline water evacuation installation. [3]

Saline water density is:

$$\rho = 1,24 \text{ kg/l} \quad (5)$$

Known parameters of aspiration heights and exhaust height are:

$$H_{\text{asp}} = 5 \text{ m} \quad (6)$$

$$H_u = 203 \text{ m} \quad (7)$$

$$H_t = 208 \text{ m} \quad (8)$$

where: H_{asp} – depth of the mine shaft sump.

H_u - height from the inferior mine level to the surface

H_t – height of the mine shaft to the surface

Flow rate of the water infiltration in the sump is calculated with one of the following formulae.

$$Q_i = Q'_i \sqrt{\frac{HS}{H'S'}} \quad [\text{m}^3/\text{h}] \quad (9)$$

where: H- sump height

S- sump surface

Q'_i - water flow rate

$$Q_i = Q_p \frac{t_2}{t_1+t_2} = 0.33 \text{ [m}^3/\text{h}] \quad (10)$$

Due to the fact that water infiltration in the sump is by condensation, it is difficult to determine flow rate, therefore the second formula was chosen, this method being water evacuation from the maximum point to a minimum inferior point in a basin. By this method the maximum point determined is 5 m high, the lowest point is 0,2 m, the basin being considered the sump where water infiltrates.

$$h_{\text{max}} = 5 \text{ m} \quad (11)$$

$$h_{\text{min}} = 0.2 \text{ m} \quad (12)$$

Working heights having been determined, the initial water volume can be thus calculated:

$$V_{\text{max}} = 60 \text{ m}^3 - \text{total sump volume} \quad (13)$$

$$V_{\text{evac}} = 57,6 \text{ m}^3 - \text{evacuated volume} \quad (14)$$

$$V_{\text{min}} = 2,4 \text{ m}^3 - \text{water volume left} \quad (15)$$

Of the total water volume, 60 m³ approximately 57,6 m³ has been evacuated, 2,4 m³ water being left.

Sump filling time by condensation and infiltration can be determined by measuring the minimum level at which it has been evacuated, up to the maximum level at which it has been refilled being 96 hours.

$$Q_i = Q_p \frac{t_2}{t_1+t_2} = 0.33 \text{ [m}^3\text{/h]} \quad (16)$$

where: Q_i – infiltration flow rate

Q_p – pump flow rate used at the trial being 2 [m³/h]

t_1 - Time required to fill the sump by condensation after it has been emptied up to the minimum level considered.

t_2 - Evacuation time of the saline water from the mine using an experimental pump with a flow rate of 2 [m³/h].

4 Constructive-functional solutions for the evacuation installation of underground water

As a result of the analytical calculations made in the previous chapter and the study of the technical offers, the following criteria should be applied in the choice of the pump in the evacuation of saline water:

- the pump should meet height criteria: evacuation at the height of 208 m, there being no possibility of placing an intermediary basin together with another evacuation pump.
- the flow rate of the pump should be minimum 2 m³/h, this not being so restrictive for us as the exhaust height.
- in order to simplify the necessity of the materials for the mounting of the exhaust pump, the diameter of the aspiration and exhaust pipe should be of the same size.
- the temperature of the evacuated liquid will be permanently 10° C, irrespective of the season, a criterion that can be met by many exhaust pumps.[3]

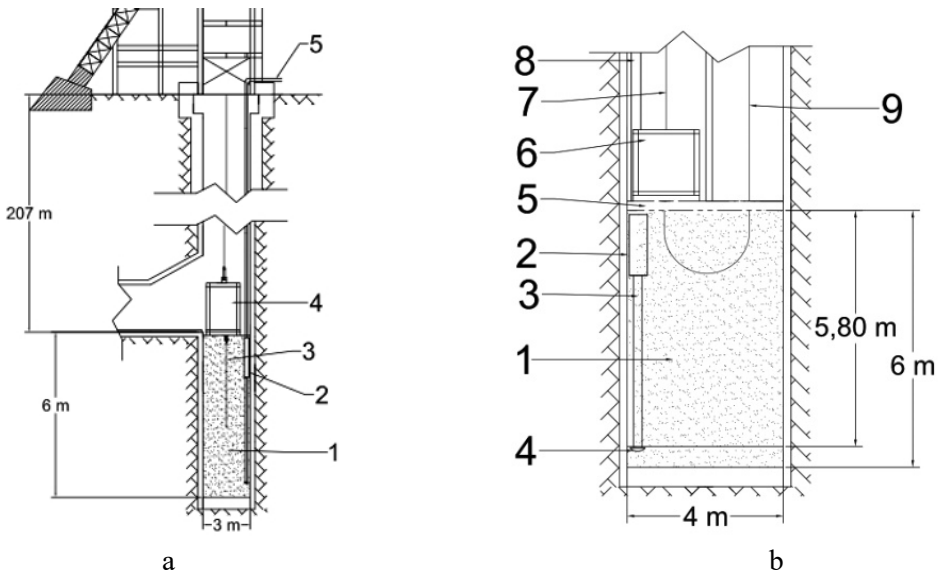

Fig. 2. a. Mine shaft and flooded sump; b. Flooded sump and position of the pump.

Figure 2.a) shows the shaft in which the saline water transportation and exhaust pipe will be placed, connected to the submersible pump, together with the admission pipe, with the following notes:

1-Unirea shaft sump, 2- SADU submersible pump anchored to the shaft wall, 3- metal balancing cables, 4- visitors transportation cage, 5- saline water evacuation pipe at the mine surface.

Figure 2.b) shows the sump in which saline water is collected, constructive dimensions together with filling and emptying dimensions being noted: 1-sump flooded with saline water, 2- submersible pump, 3- aspiration pipe of saline water, 4-suction of aspiration pipe, 5- underground level where visitors go, 6- transportation cage, 7- winding cable, 8- pump exhaust pipe, 9- balancing cable of the winding machine, linked between the two transportation cages.

Figure 3a shows Unirea Mine shaft, which is made up of 3 salt walls and the front wall is built in wood, due to the years in which salt was extracted and the shaft kept being dig, until the present level.

Figure 3b show photos from the salt mine and it is noticed that the water level is as high as the level at which visitors come out of the cage.



Fig. 3. a. Unirea Mine shaft; b. water level in the shaft sump, after 168 hours for it being drained

Table 1 shows a series of pumps for underground water evacuation, all being of the same general category, namely submersible pumps.

Table 1. Submersible pump types.

Pump type	Q-Flow rate m ³ /h	Pumping height (h)	Temp.Max. °C	Nominal pressure (Bar)	DN aspiration (mm)	DN exhaust (mm)
NDS	100-2000	25-95 m	105	10	200-400	150-350
SADU	1-80	20-220 m	130	30	50-100	40-80
SD	15-180	20-900 m	130	64-100	65-125	50-100
JIU	20-220	100-300 m	105	25;64	100-150	80-125

In table 2, technical characteristics of the motor are shown with which saline water evacuation pumps are equipped and driven.

Table 2. Technical characteristics of the electrical motor.

Tri-phase voltage		
Speeds	1500; 3000	rpm
Nominal power	75	kW
Voltage	<7.5kW	220/380
	11 kW	380/660
Frequency	50	Hz
Insulation class	B	
Protection class	IP54	

Due to the reduced water flow speed in the aspiration pipes, the diameter of those pipes will be larger than the diameter of the exhaust pipe. The calculation formula in literature is the following:

$$D = D_0 + 25 \text{ [mm]} \tag{17}$$

where: D – diameter of aspiration pipe (mm)

D₀- diameter of exhaust pipe (mm)

In choosing the diameter of the 80 mm exhaust pipe it is known that after getting out of the pump the diameter should be increased to 100 mm. The increase will be done by a diameter changing flange, for a larger flow rate, sacrificing part of the pump’s nominal pressure. The diameter of the aspiration pipe is 100 m.

As a result of the pump type analysis from the table, together with the criteria they should meet, SADU type evacuation pump has been chosen, where the height criterion is met, having the maximum exhaust height of 220 m, respectively.

Figure 4 shows the influence of flow rate related to exhaust height, for SADU pumps. Due to previous analytical calculations, the right pump is SADU 100-80.

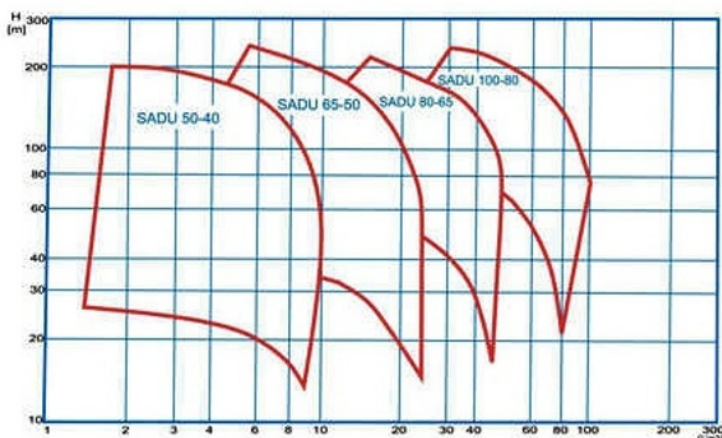

Fig. 4. Characteristic curve of Sadu submersible pumps.

The pump’s evacuation flow rate will be maximum 40 [m³/h] at 208 m exhaust height. Thus the effective water evacuation time is one hour and 13 minutes.

The maximum liquid temperature for the evacuation pump to be able to function safely is 130° C, temperature that can never be attained by the saline underground water.

Pressure losses are calculated with the formula:

$$h_{pt} = h_{local} + h_{liniar} = 70,98 \text{ m[H}_2\text{O]} \quad (18)$$

$$h_{liniar} = \lambda \cdot \frac{L}{D} \cdot \frac{v^2}{2 \cdot g} = 68.95 \text{ m[H}_2\text{O]} \quad (19)$$

v^2 – for exhaust pipe, the choice is in the range of 1.5 - 2.2 m/s² (for equation 19)

$$\lambda = \frac{0.0195}{\sqrt[3]{D}} = 0.00195 \quad (20)$$

D will be written in formula nr.17 in m.

$$h_{local} = \frac{v^2}{2 \cdot g} \cdot \sum \xi_i = 2,03 \text{ m[H}_2\text{O]} \quad (21)$$

where: $\sum \xi_i$ – sum of all local losses coefficients.

v^2 – for aspiration pipe, the choice is in the range of 0.8-1.5 m/s² (for equation 21)

$$h_{pt} = aQ^2 \text{ m[H}_2\text{O]} \quad (22)$$

Calculating the constant a, and various values being given to Q flow rate, starting with 0, h parabola can be traced, present in Fig. 6.

$$a = 0.08 \left(\frac{\lambda L}{D} + \sum \xi_i \right) \cdot D^4 = 70.98 \text{ m[H}_2\text{O]} \quad (23)$$

To determine the point of functioning of a centrifugal pump, the formula used is:

$$F = H_0 + aQ^2 = 213 \text{ m[H}_2\text{O]} \quad (24)$$

where: F- functioning point

H_0 - geodesic height.

As a result of the calculations performed, the characteristic functioning of the centrifugal pump could be traced, in concrete conditions of hydraulic networks (Figure 5).

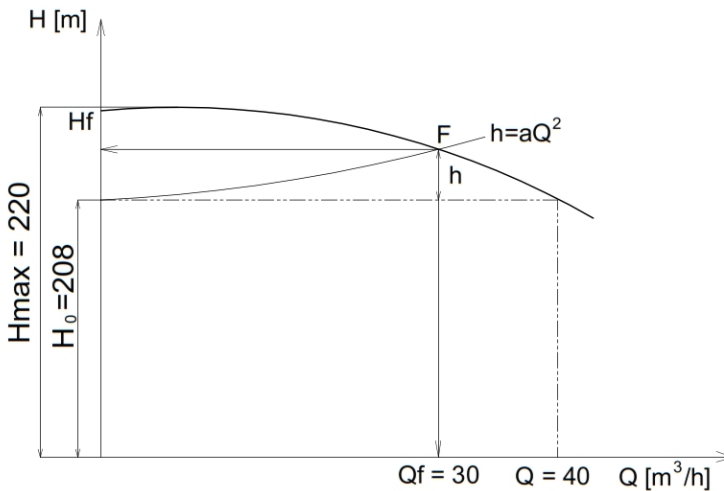

Fig. 5. Graph of functional point of SADU 100-80(100) centrifugal pump H_f and Q_f are flow rate and pressure given by the pump in concrete conditions of the hydraulic network.

Conclusion

The necessity of implementation of saline water evacuation system, from the shaft sump of Slănic Prahova salt mine comes from the fact that normal functioning of the winding installation requires this.

Metal and wood materials in the sump area are significantly deteriorated, and can be a threat for the visiting tourists transported with the winding installation, as well as for the lives of the workers, who make periodical verifications.

The effective evacuation time of saline water accumulated in the shaft sump, by the installation designed is in the range of one hour and a half, for the present infiltration rates.

Climatic changes determine a variation of the infiltration volumes, thus the installation can be started more frequently, depending on the necessities.

The evacuated flow rate by the installation is of maximum 40 m³/h, and the infiltration rate is much smaller, which confirms the correctness of the solution proposed.

References

1. C.D. Adam, *Instalații de extracție miniere*, (Editura Universitas Petroșani, 2008)
2. A. Magyari, *Instalații mecanice miniere*, (Editura Tehnica Bucuresti, 1990)
3. S.M Radu, F.D Popescu, A.I Andras, I. Kertesz, *Trasnsport si instalatii miniere*, (Editura Universitas Petrosani, 2018)