

Applying innovative technologies for road surfaces monitoring

Rustem Sakhapov^{1*}, and Marat Makhmutov¹

¹Kazan State University of Architecture and Engineering, 420043 Kazan, Russia

Abstract. The paper considers the advantages and nature of georadar monitoring of road surfaces comparing to traditional destructive methods of road exploration. The authors checked the thickness of the structural layers of pavement to determine appropriate repair work using the amplitude-frequency characteristics and the dielectric constant (the speed of signal transmission). The article examined the section of the highway and the examination data was recorded in a file, which allows further study and documentation of the material with the help of computer equipment.

1 Introduction

The purpose of the study is to increase the effectiveness of the application of georadar equipment for flaw detection of the pavement. Georadars are fixed on vehicles. During one session you can record profiles for several hundred kilometers long. Depending on the complexity of the geological conditions, one operator processes from 3 to 10 km of the recorded profile during a working day. During the road construction works, the compliance of the executed works with the approved project documentation, technical regulations and standards is estimated [13, 14]. For example, when assessing the thickness of paved bituminous concrete, the common practice is core sampling, measurement of their thickness and laboratory tests for determination of density, compaction factor and water saturation.

A great contribution to the development of georadio location and practical applications of the method was made by such scientists as A.A. Petrovsky, A.G. Tarkhov, G. Lovi and G. Leimbach, M.L. Vladov, A.V. Eremenko, R.L. Sakhapov, V.V. Silyanov and others [1-3, 4, 7-9, 12].

The principle of operation of radars is based on the emission of ultra-wideband electromagnetic pulses without a carrier into the underlying medium and recording their reflections from the interfaces of layers or objects.

The propagation velocities of longitudinal C_p and (more rarely) transverse C_s elastic waves are used as informative parameters of ultrasonic (US) control, as well as their attenuation coefficients a_p and a_s respectively. The frequency range used in measurements in an array is usually 30 to 150 kHz [4].

* Corresponding author: rusakhapov@gmail.com

2 Material and methods

When determining the stresses in the contour rock massif, depending on the measurement scheme being implemented, the following methods are distinguished:

- the method of ultrasonic transmitted waves;
- ultrasonic logging method;
- the method of reflected waves.

The method of ultrasonic passing waves (sounding) occupies a dominant position among ultrasonic methods of geocontrol. This is due, on the one hand, to the most perfect methodological and hardware support, and on the other hand to the possibility of using these methods in a wide range of controlled bases (from a few centimeters to several meters) both on samples and in an array rocks (variant of interwell sounding) [3].

One of the most frequently solved problems with the use of ultrasonic methods of geocontrol - study the nature of the spatial distribution of stresses in the environments of the excavations and its dynamics over time.

The sequence of operations for the implementation of measurements by the sounding method is as follows. From the mine workings to the array, a set of parallel holes is drilled in a triangular or circular pattern, as shown in fig.1. Then the borehole probes are placed in parallel boreholes. The acoustic transducer in one of the probes is used as a radiator for pulsed ultrasonic vibrations, and in the second - as a receiver. Then the probes move synchronously and discretely into the interior of the array. Measurement of the spatial distribution of informative parameters of ultrasonic testing, most often the value of C_p , reflects the spatial distribution of stresses.

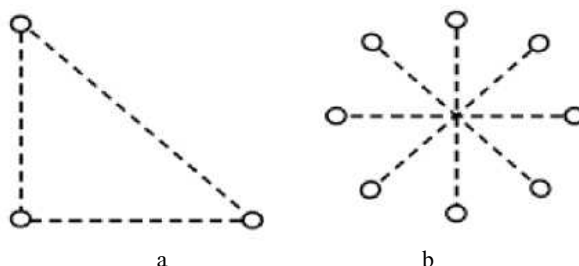

Fig. 1. The location of the boreholes: a - in a triangular pattern; b - along a circular pattern.

US logging is a downhole method of geophysical studies, based on the study of the acoustic properties of rock formations intersected by the well and directly adjacent to it. The implementation of this method involves the use of a single borehole probe in which the radiator and one or several receivers of ultrasonic pulse signals are placed.

Such a probe moves along a linear profile located on the axis of the water-filled or forming a dry well. By the nature of the distribution of measured acoustic characteristics along the profile, the nature of the distribution of stresses in the contour array is judged. [13, 14]

The ultrasonic wave reflection method assumes radiation into the controlled region of the mass and subsequent recording of the ultrasonic signal reflected from the natural or artificial inhomogeneity in it. The method has a relatively limited application in the study of the geological environment, which can be explained by the significant loss of signal power on the doubled base of its propagation (from a combined acoustic transducer to reflective heterogeneity and vice versa), and also at the boundary between the host geomedium and heterogeneity, since the reflection coefficient from the latter can be much less than unity. In terms of amplitude-frequency characteristics, dielectric permeability (speed of signal transmission) in various soils, the soil type, its humidity and relative density are determined [6].

3 Theory

The main characteristic describing the degree of conductivity of asphalt concrete is the volume specific resistance, defined by the formula:

$$P_v = \frac{R_v \cdot S}{h}, \tag{1}$$

where R_v – volume resistance of the sample, Ohm; S – electrode space, m^2 ; h – sample’s thickness, m.

The electrical resistance depends on the mineral composition of the asphaltic concrete and varies widely. So, for gravel and rubble, which are conductors, $P_v \sim 10^{-5}$ Ohm · m, and for some components characterized by dielectric properties, $P_v \sim 10^{17}$ Ohm · m.

To solve the problems of determining the stress state of an array, it is important that the changes in the resistivity with increasing pressure in different materials can have a different character [5]. During the road surface observation, there was developed geological research equipment for flaw detection of the pavement (Fig. 2.). For this purpose the device uses two geological prospecting sensors [7]. The principle of the georadar is based entirely on radiolocation: radiation and fixation of reflected electromagnetic pulses. The impulse is produced by the device itself and, with the aid of a radiator (antenna), is sent to the studied environment.

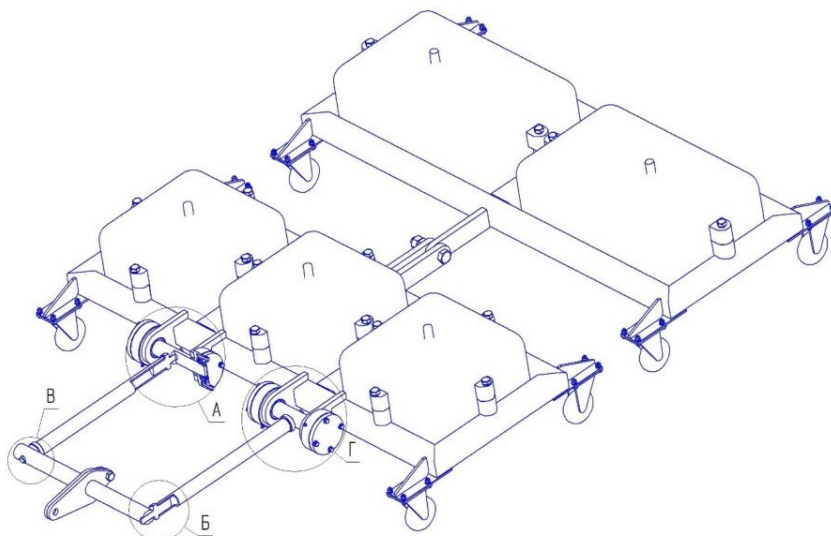

Fig. 2. General device of equipment for flaw detection.

Practical importance are linear vertical body movements (rocking), its angular oscillations in the longitudinal plane of the vehicle (galloping), angular oscillations in the transverse plane (teeter), the oscillation axes (bridges) in the vertical plane.

Frequency of the disturbing force at periodic influence of roughness of the road on wheels of the caris found by the formula:

$$n_v = \frac{2\pi \cdot V}{3,6S}, \tag{2}$$

where V – speed, km / h; S – length of roughness, m.

The functional view of the minimal components of the georadar OKO-2 is shown in fig. 3. As a rule, the package includes a base set and one or more antenna blocks: a control unit; antenna unit; optical converter; registration device (laptop and 2 mini-cameras); block of

processing (control and processing unit); power supply unit with chargers; motion sensors; cables. Were applied two branch road methods: "Methodological recommendations for the application of georadars in the research of road structures" and ODM 218.2.037-2013 "Methodological recommendations for conducting survey work in the repair and repair of highways".

The relationship between the frequency of the disturbing force, the size of the roughness of the roadway and the speed Of R. V. Rotenberg recommends to establish the characteristics of the smoothness of the car.

Taking into account the influence of acceleration and oscillation frequency of the car on the functional state of the drivers, the regulatory requirements for the longitudinal evenness of the operated roads are developed, taking into account the traffic intensity, road category and type of coverage for each method and measuring device.

The environment can be any material: concrete, soil, brick wall, etc. When scanning, the computer screen displays a radargram in the course of georadar movement, where in-phase lines are recorded in the form of black-and-white or colored bands, as well as noise [13, 14]. The distance traveled by the georadar, the depth of sounding, the time of passage of the signal and special marks are indicated on a radargram, as a rule. Control drilling can be performed before scanning, during scanning and after scanning.

If the design information is unknown, then the test drilling can be performed before scanning. To do this, it is necessary to record the radargram on a short section, to allocate a homogeneous plot on it, mark it on the terrain and perform the control drilling. Based on the drilling results, adjustments should be made to the initial settings of the GPR.

Interpretation is reduced to the solution of the inverse physical and mathematical problem, which results in a formulation of an electrophysical model, and then - a section of the road structure. At this stage, taking into account the drilling data, the propagation velocities of electromagnetic waves in the layers and their thicknesses are being determined. The solution of the inverse problem is usually carried out in several stages, each of which contains the stages of processing and interpretation. The processing of field radargrams is performed in the case when interfering waves make it difficult to identify and trace useful waves. It should be borne in mind that as a result of processing, some of the information, including useful, is inevitably lost. The treatment procedure is divided into two stages: preliminary processing and information analysis. Interpretation of results is a process of constructing a section of pavement and consists of two main stages: kinematic and dynamic. The kinematic interpretation allows, according to the recorded times of useful waves, to restore the position of the boundaries and the distribution of the velocities of electromagnetic waves in the layers of the road structure.

Contact antennas are recommended when performing detailed surveys of areas up to 2 km (both fixed to the car and by means of manual towing), as well as if it is necessary to carry out cross passages (with manual towing of the georadar).

At the same time, the economic effect in the research of 10 km of road structures using georadar technologies reaches at least 2.5 million rubles due to a reduction in the number of drilling operations and core sampling. Moreover, preliminary calculations show that the costs for subsequent maintenance work will decrease by at least 20 percent. Calculations also show that, by laying the track even 13% longer, but under the best soil and hydrogeological conditions, it is possible to save considerably on operating costs in the life cycle of the road, avoiding large expenses and protracted repair work.

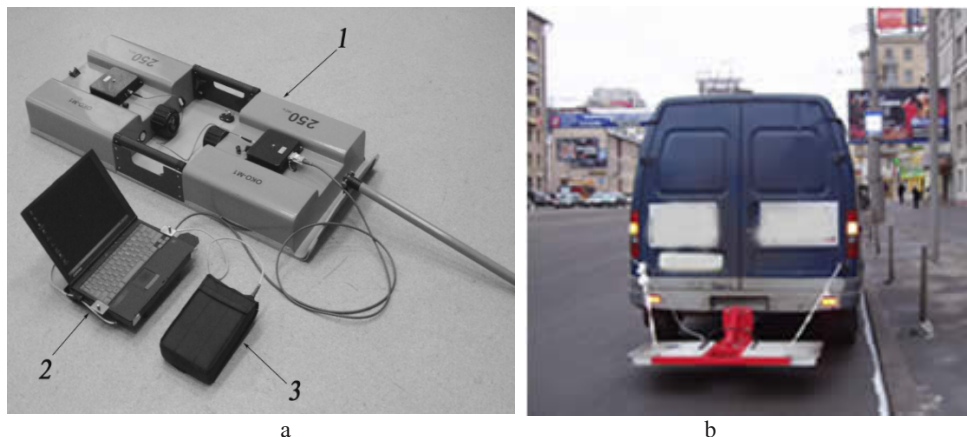

Fig. 3. Working set of a georadar OKO-2 (a) and operation on a «Gazelle» car (b): 1- an antenna unit including a transmitting and receiving antenna; 2 - device for collecting and processing information; 3 - external rechargeable battery.

4 Results

During the inspection a section of the highway in the Apastovsky District of the Republic of Tatarstan, the georadar worked using an antenna block with a frequency of 2500 MHz. The task of the study was to check the thickness of constructive layers of pavement for the purpose of assigning appropriate repair work, if necessary. The survey was conducted at an air temperature of +15 ° C, scanning at a speed of 30 to 35 km/h. The used method suggested continuous georadar scanning of the engineering geological section along the lines of profiles passing in the middle of each lane of the road. In the process of georadar movement, the laptop displayed a program with fixed lines of in-phase in the form of black-and-white or color bands and the noise. The radargram also showed the distance traveled by geo-radar, the depth of sounding, the time of the signal passage and special marks (Fig. 4).

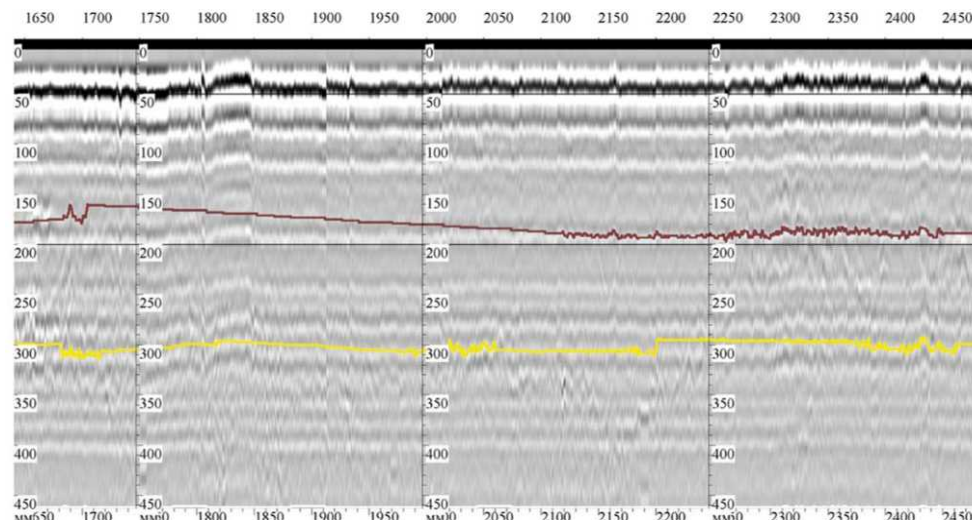

Fig. 4. Radargram with fixed in-phase lines.

Analysis of radargrams in this section of the road in the longitudinal direction showed that the thickness of the asphalt concrete layer along the length of the road varies from 12 to

20 cm, and the thickness of the bed of crushed stone in the range of 12.0-18.0 cm. At the beginning of the section, the thickness of the asphalt concrete layer under the central lane of movement was 5 cm thicker than under the extreme bands and 10 cm thicker in the middle of the section.

The method of georadiolocation is based on the study of the field of high-frequency electromagnetic waves [10]. The method relies on the difference in the rocks from the dielectric constant [11]. The radiated impulse, propagating in the environment or object under examination, is reflected from the boundaries with the change of the electrical characteristics - electrical conductivity and dielectric constant [13-16]. The reflected signal is being received by the receiving antenna, and then amplified, digitized and stored. The frequency of the probing impulse of the georadar is in the range from 25 MHz to 3 GHz, the wavelengths in the investigated environmentd are in the range from several centimeters to several meters. The resolving power of georadar in depth research can be improved during the mathematical processing of the field material.

5 Conclusion

Monitoring of the road section with the georadar method allows us to draw the following conclusions:

- destruction of asphalt concrete pavement is associated with non-compliance with the thickness of the road structure;
- designation of the appropriate type of repair work will allow to extend the life of the pavement.

For the wide application of georadar technologies, we advise to develop a sectoral five-year scientific and technical program for the introduction of georadar technologies. The program envisages research on the development of multipurpose mobile georadar laboratories; improvement of software for automatic recognition of abnormal zones; determination of the physico-mechanical properties of road-building materials and soils by amplitude-frequency characteristics, etc.

Economic calculations have shown that the proposed version of the equipment for roadway defecting is more efficient and rational, the equipment is cheaper in value. Monitoring can identify the true causes of road damage and won't affect the environment. Based on the results of monitoring, it is possible to assign effective types of corresponding repair work that will ensure the operational reliability of highways for a longer period. Consequently, production and monitoring with the developed equipment is expedient and economically justified.

References

1. R.L. Sakhapov, S.G. Absalyamova, *The use of telecommunication technologies in education network*, Proceedings of 2015 12th International conference on Remote Engineering and Virtual Instrumentation. Bangkok. REV 2015. 25-27 February 2015. P. 14-17. (2015)
2. A.I. Brekhman, R.L. Sakhapov, S.G. Absalyamova, *Innovative model of integration of education and business in the road construction industry*. International Journal "Science & Engineering for Roads", **3 (69)**. P. 39-41. (2014)
3. M.L. Vladov, A.V. Starovoitov, *GPR studies upper part of the section*. M. Mosk. University press. (2002)
4. A.V. Eremenko, E.A. Zverev, S. M. Klepikova, *Osipenko M. M. GPR research in*

- terms of reinforcement*. The report at the conference. «Georadar-2004».
5. M.M. Makhmutov, *Optimization of parameters of taper of the strut device chains*. Tractori i chelhozmachinye. Moscow, **6**, p. 31-33 (2013)
 6. *Methodical recommendations about application of GPR at inspection of road designs*. Moscow. Rosavtodor, p. 64-75. (2004)
 7. R.L. Sakhapov, M.M. Makhmutov, *Influence of the studied factors on productivity of a road mill*. Izvestiya KGASU. Kazan, **4(30)**, P. 497-502 (2014)
 8. R.L. Sakhapov, T.R. Gabdullin, R.V. Zagretdinov, *the Modeling of control systems of road-building equipment*, Izvestiya Samarskogo nauchnogo centra RAN. Samara.. vol. 16. **1 (2)**. P. 394-396 (2014)
 9. V.V. Silyanov, L.N. Sapegin, *Modeling algorithm for the study on EVM impact of the road conditions and means of regulation on the flow of cars*. Trudy MADi, Moscow, **52**, P. 139-148 (1973)
 10. Y.M. Sitnikov, O.A. Devochkin, V.V. Silyanov, *Stage-by-stage improvement of transport and operational qualities of roads*. M. Transport (1975).
 11. N.P. Semeykin, V.V. Pogosov, *Survey of roads with the georadar method*. M.: Mir dorog (2004)
 12. R.V. Nikolaeva, R.L. Sakhapov, T.R. Gabdullin, M.M. Makhmutov, *Motor Roads As a Factor of the Economic Potential of the Republic of Tatarstan*, International Conference on Applied Economics, ICOAE 2015, **24**, P.606-612 (2015)
 13. R.L. Sakhapov, R.V. Nikolaeva, M.H. Gatiyatullin, M.M. Makhmutov, *Risk management model in road transport systems*, Journal of Physics: Conference Series, **738 (1)**, pp. 012008 (2016)
 14. R.L. Sakhapov, R.V. Nikolaeva, M.H. Gatiyatullin, M.M. Makhmutov, *Modeling the dynamics of the chassis of construction machines*. Journal of Physics: Conference Series, **738 (1)**, pp. 012119, (2016)
 15. R.L. Sakhapov, R.V. Nikolaeva, M.H. Gatiyatullin, M.M. Makhmutov, *Mathematical model of highways network optimization*, Journal of Physics: Conference Series, 738 (2), pp. 012009 (2017)
 16. R.L. Sakhapov, R.V. Nikolaeva, M.H. Gatiyatullin, M.M. Makhmutov, *Modeling of traction-coupling properties of wheel propulsor*, Journal of Physics: Conference Series, **738 (2)**, pp. 012115. (2017)