

Processing of the edges of the parts on the robot complex

Dmitriy Podashev^{1,*} and *Yuriy Dimov*¹

¹Irkutsk National Research Technical University, 83 Lermontov street, 664074, Irkutsk, Russia.

Abstract. In some fields of industry (especially in aircraft- and helicopter buildings) high requirements are made to the quality of the processed parts surfaces on the final operations. At the same time many operations (surface conditioning, edge cutting, radiussing etc) are done manually with expenditure of sufficient manpower. That's why problem of mechanization and automatization of such final operations for these industries is very acute.

We consider the possibility of fulfillment of such operations on the parts of the aircraft with use of robot complex (RC).

The researches were conducted on the RC shown on Fig.1 and consisting of the following:

- robot KUKA KR 210 R2700 EXTRA (Germany) with control system KR C4, radius of action – 2696 mm, 6-axles, software - Windows XPe;
- electrospindle made by "Elettromeccanica Giordano Colombo" (Italy), model RC90 with rate of rotation – 240–24000 min⁻¹, nominal output – 4 KW, with change of tool (several magazines with 3 tools per one magazine), with grips Ø2–16 mm, maximum tool diameter – 380 mm;
- table made by "Forster" (Germany) with dimensions 4000x1500 mm.

Taking into consideration fragility and vibration resistance of the robot with installed electrospindle balancing of the tool is provided on the module balance system Haimer TD2009 Comfort Plus (Germany) with operating rotations of the spindle – 300 – 1100 min⁻¹, maximum length of the tool – 400 mm, accuracy of measurement < 0,5 gmm. The balancing was done in accordance with Russian GOST ISO 1940-1-2007 «Vibration. Requirements to quality of balancing of rigid rotors. Part 1. Detection of allowable misbalance" by class of accuracy of balancing G6,3.

The polymeric abrasive brushes are considered to be the most effective instrument for processing of the edges of the part as the researches shown [1, 2, 3, 4].

At the present time such brushes are produced by several companies: 3M (Minnesota Mining and Manufacturing Company), C. Hilzinger-Thum, August Rugeberg PFERD-Werkzeuge, OSBORN International, LIPPERT UNIPOL, HOFFMANN GROUP, JAZ, Hommel Hercules Werkzeughandel, Eisenblatter etc.

* Corresponding author: dbp90@mail.ru



Fig. 1. RC with use of industry robot KUKA KR 210 R2700 EXTRA

In our researches one-piece cast end brushes BD-ZB made by 3M (Minnesota Mining and Manufacturing Company) (Fig. 2) were used. The brush is made of polymer, along which are evenly distributed grades of pyramid form of high-capacity and wearproof abrasive material 3M Cubitron™.

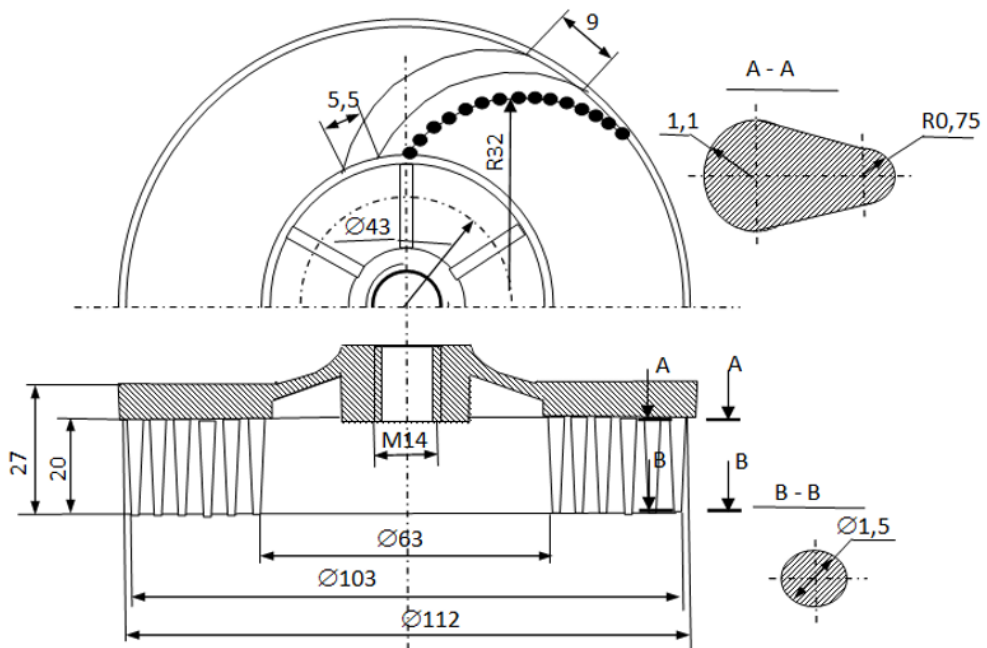

Fig. 2. End brush BD-ZB consisting of 36 rows, in one row - 15 hairs, total 540 hairs

Experimental researches were conducted on samples made of high-strength aluminum alloy V95pchT2 and titanium alloy VT-20 in training programming mode of the processing.

Dimensions of the processed edge X, Y and p (Fig. 3) were measured on big instrumental microscope BMI -1C (Russia) with scale gradation of 1 micron.

Research of processing of edges on RC were conducted as per scheme given in Fig.4 with dimension A=45 mm with end brushes BD-ZB Bristle P50, BD-ZB Bristle P80 and BD-ZB Bristle P120.

Efficiency of the processing of edges was evaluated by average size of part edge by axles X and Y that is defines as follows:

$$Z_k = (X+Y)/2, \tag{1}$$

where X, Y – dimensions of edge as per axles (see Fig. 3).

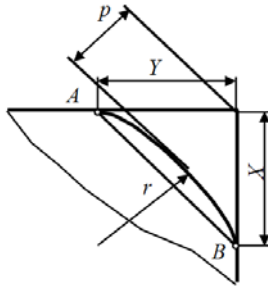

Fig. 3. Scheme for detection of parameters of radiussing

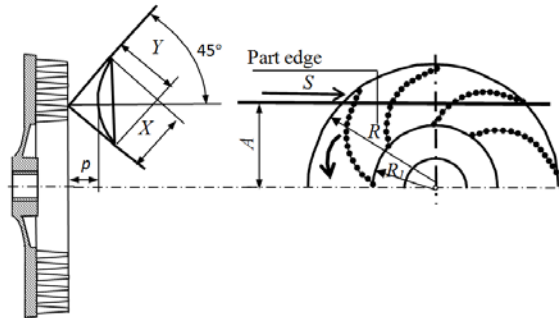

Fig. 4. Scheme of processing of the edge of the end brush

The extreme dependencies of the edge size from rate of rotation when processing both with V95pchT2 and VT-20 were determined in the process of conducted researches (Fig.5). It was connected with delay of straightening of hairs after touching the edge and as a result of it the next touching occurs with less hairs' deformation and as a consequence with less force of interconnection with the edge.

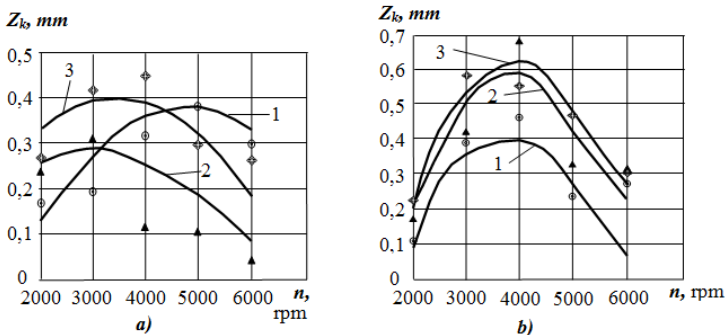

Fig. 5. Dependencies Z_k from the rate of rotation of the end brush at $\Delta Y=1,5$ mm; $A=45$ mm: a – for V95pchT2 at $S=400$ mm/min; b – for VT-20 at $S=200$ mm/min; 1 – BD-ZB Bristle P50; 2 – BD-ZB Bristle P80; 3 – BD-ZB Bristle P120

On the basis of these data, it can be considered that rate of rotation more than 4000 rpm is not recommended for use.

Dependency of the edge size from the brush deformation is given on Fig.6. The size of edge increases with increase of cutting force [6].

The edge size decreases with increase of feeding (Fig.7).

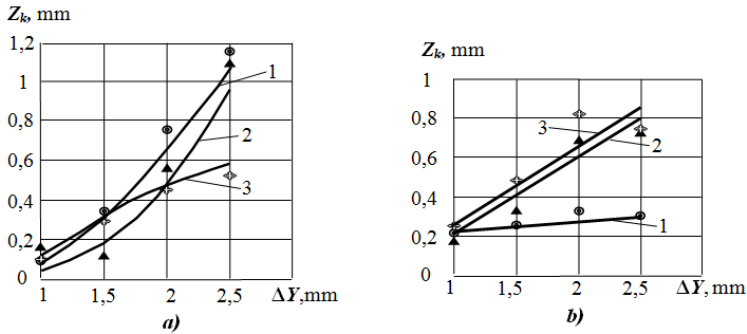

Fig. 6. Dependencies Z_k from deformation of end brush at $n=5000$ rpm; $A=45$ mm: *a* – for V95pchT2 at $S=400$ mm/min; *b* – for VT-20 at $S=200$ mm/min: 1 – BD-ZB Bristle P50; 2 – BD-ZB Bristle P80; 3 – BD-ZB Bristle P120

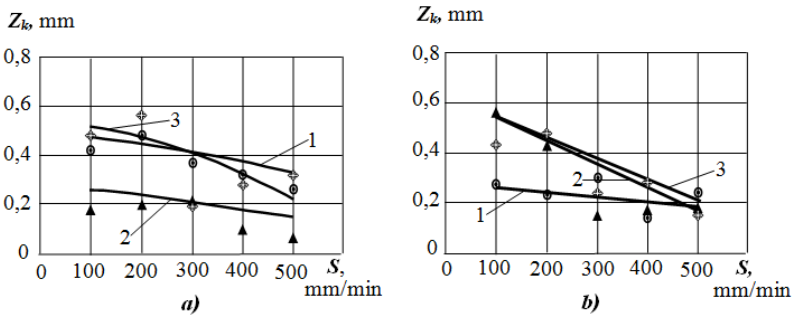

Fig. 7. Dependencies Z_k from feeding of the end brush at $n=5000$ rpm; $\Delta Y=1,5$ mm; $A=45$ mm: *a* – for V95pchT2; *b* – for VT-20: 1 – BD-ZB Bristle P50; 2 – BD-ZB Bristle P80; 3 – BD-ZB Bristle P120

On received experimental data including the corresponding statistic processing a equation has been made for detection of the edge Z_k size depending on rate of rotation n , brush deformation ΔY and feeding S .

$$Z_k = a_1 \cdot \Delta Y^2 + a_2 \cdot n^2 + a_3 \cdot S^2 + a_4 \cdot \Delta Y + a_5 \cdot n + a_6 \cdot S + a_7 \cdot \Delta Y \cdot n + a_8 \cdot \Delta Y \cdot S + a_9 \cdot n \cdot S + a_{10} \cdot \Delta Y \cdot n \cdot S + a_{11}. \quad (2)$$

Meanings of coefficients a_{1-10} , and absolute term a_{11} in this equitation are given in Table 1.

In case of necessity to achieve the required size of the edge Z_k regulation of the processing can be done by using any parameter, for example – feeding S .

At assigned Z_k , ΔY and n feeding S is detected by the equation:

$$S = (-d + \sqrt{(d^2 - 4 \cdot a_3 \cdot f)}) / 2 \cdot a_3, \quad (3)$$

where $d = a_6 + a_8 \cdot \Delta Y + a_9 \cdot n + a_{10} \cdot \Delta Y \cdot n$;

$f = a_1 \cdot (\Delta Y)^2 + a_2 \cdot n^2 + a_4 \cdot \Delta Y + a_5 \cdot n + a_7 \cdot \Delta Y \cdot n + a_{11} - Z_k$.

Roughness of the edge surface was measured on the optical profilometer Bruker Contour GT-K1.

Researches of roughness Ra when processing with end brushes BD-ZB Bristle P50, BD-ZB Bristle P80 and BD-ZB Bristle P120 showed that the parameter Ra changes with increase of the rate of rotation with extreme dependency (Fig. 8).

Table 1. Meanings of coefficients and an absolute term in (2).

| Coefficient and an absolute term | V95pchT2 | | | VT-20 | | |
|----------------------------------|------------------------|----------------------|----------------------|------------------------|-----------------------|----------------------|
| | Instrument – end brush | | | | | |
| | BD-ZB Bristle P50 | BD-ZB Bristle P80 | BD-ZB Bristle P120 | BD-ZB Bristle P50 | BD-ZB Bristle P80 | BD-ZB Bristle P120 |
| a_1 | 0,06 | 0,31 | -0,05 | -0,01 | -0,04 | -0,06 |
| a_2 | $-3,2 \cdot 10^{-8}$ | $-2,1 \cdot 10^{-8}$ | $-3 \cdot 10^{-8}$ | $-1,005 \cdot 10^{-7}$ | $-1,18 \cdot 10^{-7}$ | $-1,3 \cdot 10^{-7}$ |
| a_3 | $-6 \cdot 10^{-7}$ | $-7 \cdot 10^{-8}$ | $-4 \cdot 10^{-7}$ | $-2 \cdot 10^{-7}$ | $1 \cdot 10^{-6}$ | $-8 \cdot 10^{-7}$ |
| a_4 | 0,486 | -0,455 | 0,475 | 0,089 | 0,528 | 0,618 |
| a_5 | $3,1 \cdot 10^{-4}$ | $1,2 \cdot 10^{-4}$ | $2 \cdot 10^{-4}$ | $7,6 \cdot 10^{-4}$ | $8,9 \cdot 10^{-4}$ | $1 \cdot 10^{-3}$ |
| a_6 | $1 \cdot 10^{-4}$ | $-1 \cdot 10^{-4}$ | $-6 \cdot 10^{-4}$ | $-8 \cdot 10^{-5}$ | $-1,5 \cdot 10^{-3}$ | $-4 \cdot 10^{-4}$ |
| a_7 | $1,5 \cdot 10^{-9}$ | $1 \cdot 10^{-9}$ | $1 \cdot 10^{-9}$ | $1,5 \cdot 10^{-9}$ | $1 \cdot 10^{-9}$ | $1 \cdot 10^{-9}$ |
| a_8 | $-2,41 \cdot 10^{-9}$ | $-3,5 \cdot 10^{-9}$ | $-3,5 \cdot 10^{-9}$ | $-2,41 \cdot 10^{-9}$ | $-3,5 \cdot 10^{-9}$ | $-3,5 \cdot 10^{-9}$ |
| a_9 | $5,8 \cdot 10^{-11}$ | $6,5 \cdot 10^{-11}$ | $6,5 \cdot 10^{-11}$ | $5,8 \cdot 10^{-11}$ | $6,5 \cdot 10^{-11}$ | $6,5 \cdot 10^{-11}$ |
| a_{10} | $1,5 \cdot 10^{-11}$ | $1,5 \cdot 10^{-11}$ | $1,5 \cdot 10^{-11}$ | $1,5 \cdot 10^{-11}$ | $1,5 \cdot 10^{-11}$ | $1,5 \cdot 10^{-11}$ |
| a_{11} | -1,18 | 0,15 | -0,23 | -1,135 | -1,52 | -1,96 |

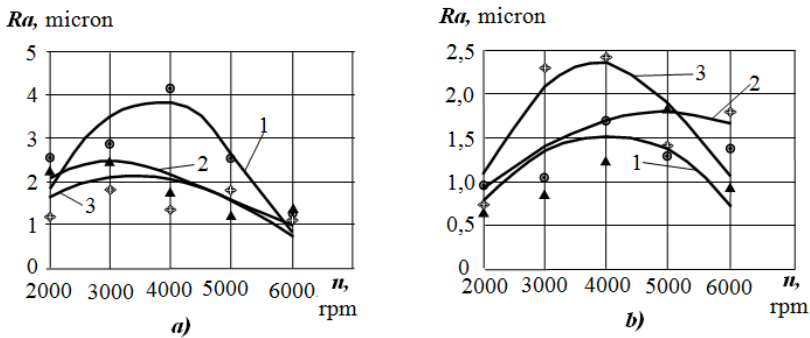

Fig. 8. Dependencies Ra from rate of rotation of end brush at $\Delta Y=1,5$ mm; $A=45$ mm: a – for V95pchT2 at $S=400$ mm/min; b – for VT-20 at $S=200$ mm/min: 1 – BD-ZB Bristle P50; 2 – BD-ZB Bristle P80; 3 – BD-ZB Bristle P120

It is connected with delay of straightening of hairs after touching the edge and as a result of it the next touching occurs with less hairs' deformation and as a consequence with less force of interconnection with the edge.

The brush deformation directly leads to proportional changing of roughness that is proved by dependencies in Fig.9. More feeding – less roughness (Fig.10).

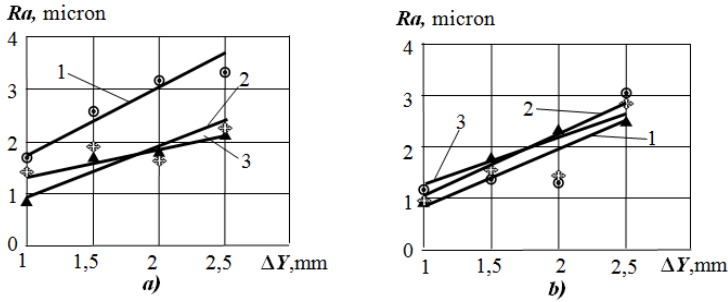

Fig. 9. Dependencies Ra from deformation of end brush at $n=5000$ rpm; $A=45$ mm: a – for V95pchT2 at $S=400$ mm/min; b – for VT-20 at $S=200$ mm/min: 1 – BD-ZB Bristle P50; 2 – BD-ZB Bristle P80; 3 – BD-ZB Bristle P120

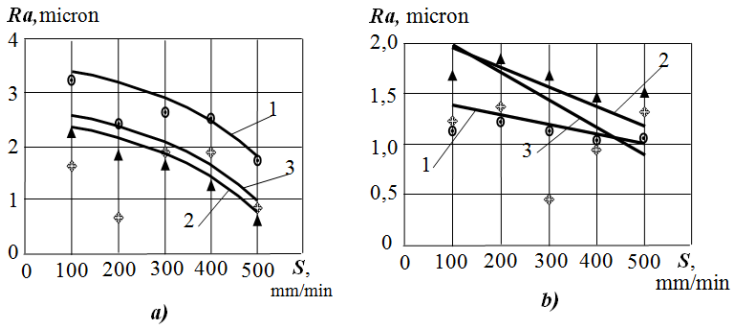

Fig. 10. Dependencies Ra from feeding of feed brush at $n=5000$ rpm; $\Delta Y=1,5$ mm; $A=45$ mm: a – for V95pchT2; b – for VT-20: 1 – BD-ZB Bristle P50; 2 – BD-ZB Bristle P80; 3 – BD-ZB Bristle P120

On received experimental data including the corresponding statistic processing an equation has been made for detection of the roughness parameter Ra depending on rate of brush rotation n , brush deformation ΔY and feeding S .

$$Ra = a_1 \cdot \Delta Y^2 + a_2 \cdot n^2 + a_3 \cdot S^2 + a_4 \cdot \Delta Y + a_5 \cdot n + a_6 \cdot S + a_7 \cdot \Delta Y \cdot n + a_8 \cdot \Delta Y \cdot S + a_9 \cdot n \cdot S + a_{10} \cdot \Delta Y \cdot n \cdot S + a_{11}. \quad (4)$$

Meanings of coefficients a_{1-10} , and absolute term a_{11} in this equation are given in Table 2.

It is necessary to mention that end brush can process hard to reach areas of the part in comparison with radial brushes. Processing of such edge is shown in Fig. 11.

Use of other elastic instruments (considered in the research) [1]: besides brushes is possible with RC.

Instruments made of grit paper and abrasive-carrying cloths: cones, tubes, caps, shells, discs (hook-face, with perforations).

Circles with abrasive covering: covering with grit paper (felt, rubber, paralon, air cylinders), covered with layer of abrasive (felt, rubber, paralon, polyurethane).

Flap disks: made of grit paper, grit paper with slots, grit paper of V-form, sisal with grit paper, molded fabric, polymeric abrasive bands.

Abrasive-carrying circles: on the basis of froth polyurethane and other synthetic materials, on bunch of foamed plastics, made of molded fabric (with synthetic or nature fibers, with non-stick and antistatic additives).

Table 2. Meanings of coefficients and an absolute term in (4)

| Coefficient and an absolute term | V95pchT2 | | | VT-20 | | |
|----------------------------------|------------------------|-----------------------|-----------------------|-----------------------|-----------------------|-----------------------|
| | Instrument – end brush | | | | | |
| | BD-ZB Bristle P50 | BD-ZB Bristle P80 | BD-ZB Bristle P120 | BD-ZB Bristle P50 | BD-ZB Bristle P80 | BD-ZB Bristle P120 |
| a_1 | -0,3 | -0,2 | -0,2 | 0,1 | -0,3 | -0,2 |
| a_2 | $-7 \cdot 10^{-7}$ | $-3 \cdot 10^{-7}$ | $-1,9 \cdot 10^{-7}$ | $-2 \cdot 10^{-7}$ | $-1 \cdot 10^{-7}$ | $-4 \cdot 10^{-7}$ |
| a_3 | $-9 \cdot 10^{-6}$ | $-6,5 \cdot 10^{-6}$ | $-6,5 \cdot 10^{-6}$ | $-1 \cdot 10^{-6}$ | $-7 \cdot 10^{-7}$ | $-3 \cdot 10^{-6}$ |
| a_4 | 2,19 | 1,54 | 1,22 | 0,75 | 1,95 | 1,9 |
| a_5 | $5,1 \cdot 10^{-3}$ | $1,9 \cdot 10^{-3}$ | $1,3 \cdot 10^{-3}$ | $1,6 \cdot 10^{-3}$ | $1 \cdot 10^{-3}$ | $3 \cdot 10^{-3}$ |
| a_6 | $1,5 \cdot 10^{-3}$ | $2 \cdot 10^{-4}$ | $1 \cdot 10^{-4}$ | $-3 \cdot 10^{-4}$ | $-1,7 \cdot 10^{-3}$ | $-7 \cdot 10^{-4}$ |
| a_7 | $1,5 \cdot 10^{-9}$ | $1,5 \cdot 10^{-9}$ | $1,5 \cdot 10^{-9}$ | $1,5 \cdot 10^{-9}$ | $1,5 \cdot 10^{-9}$ | $1,5 \cdot 10^{-9}$ |
| a_8 | $-2,41 \cdot 10^{-9}$ | $-2,41 \cdot 10^{-9}$ | $-2,41 \cdot 10^{-9}$ | $-2,41 \cdot 10^{-9}$ | $-2,41 \cdot 10^{-9}$ | $-2,41 \cdot 10^{-9}$ |
| a_9 | $5,8 \cdot 10^{-11}$ | $5,8 \cdot 10^{-11}$ | $5,8 \cdot 10^{-11}$ | $5,8 \cdot 10^{-11}$ | $5,8 \cdot 10^{-11}$ | $5,8 \cdot 10^{-11}$ |
| a_{10} | $1,5 \cdot 10^{-11}$ | $1,5 \cdot 10^{-11}$ | $1,5 \cdot 10^{-11}$ | $1,5 \cdot 10^{-11}$ | $1,5 \cdot 10^{-11}$ | $1,5 \cdot 10^{-11}$ |
| a_{11} | -7,27 | -1,4 | -0,5 | -2,95 | -2,58 | -5,34 |

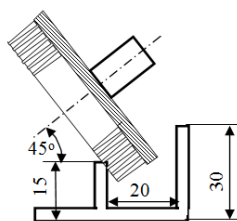

Fig. 11. Scheme of processing of hard to reach rectilinear edge

Conclusion

Robotic automation of final processing of parts edges with polymer and abrasive instruments is one of the perspective trends of replacement of manual labour to mechanized and automatic ones.

It is proved that processing of edges with robot can be done successfully with end brushes at high velocities (up to 6000 rpm) and high quality of processed surface in spite of decreased rigidity and increased sensibility to oscillatory occurrences if compare with other metal-cutting equipment. Hence RC (at corresponding instrument balancing) can be successfully used under industry conditions. At this the received regressive equations of size and

roughness of processed edge for end brushes allow to control effectively the productivity of the process and roughness of the processed edge with mode parameters of processing.

References

1. Yu.D. Abrashkevich, G.M. Machishin. Effective utilization of an abrasive brush. *Bulletin of Kharkov National Automobile Road University*. v. 73. pp. 59–62 (2016)
2. D.F. Ustinovich, V.I. Pribylsky, A.G. Mochailo. Elastic polymer abrasive instrument with discrete cutting circuit. *Mechanical engineering and technosphere of XXI century: collection of works of 15th international scientific conference, Sevastopol, 15 – 20 September, 2008: in 4 volumes. DonSTU. Donetsk. Volume. 3. pp. 241 – 244 (2008).*
3. Yu. V. Dimov. *Machining of parts by elastic instrument: reference book*. Irkutsk. publishing house of ISTU. 484 p (2013).
4. D.B. Podashev. *Final machining of parts by elastic polymer abrasive instruments: monography*. Irkutsk. Publishing house of INRTU. 246 p (2018).
5. Yu. V. Dimov, D.B. Podashev. Edge forces in machining by polymer abrasive brushes. *The messenger of mechanical engineering*. No. 11. pp. 59-63 (2016).
6. Yu. V. Dimov, D.B. Podashev. Edge forces in machining by end brushes. *The messenger of mechanical engineering*. Vol. 21. № 12. pp. 22-42 (2017).