

Failure of the overhead crane runway

Pawel Kossakowski^{1,*}, *Wiktor Wciślik*¹, and *Michał Bakalarz*¹

¹Kielce University of Technology, Faculty of Civil Engineering and Architecture,
al. Tysiąclecia Państwa Polskiego 7, 25-314 Kielce, Poland

Abstract. The paper reports a failure of the overhead crane runway. Failures of this type often occur in industrial buildings that have been in operation for a long period of time. The reasons are dynamic, fatigue-related phenomena in crane operations, and also design and structural errors. An important issue is also the presence of geometric notches, which promote the formation of fatigue cracks, accelerating the process of degradation of the structure. Visual inspection of the overhead crane runways revealed loosening and failure of rail – beam connections, and also substantial horizontal and vertical displacements of the rails. Additionally, geodetic measurements of rail arrangement were taken. They indicated the exceeding of permissible deviations for rails spacing and vertical arrangement stated in the relevant standards. The runway damages resulted from dynamic character of the loads applied. In some cases, high crane travel speed and acceleration produced impact forces that affected the runway structure. Vertical and horizontal deformation of rails was an additional source of impact in the crane runs. Another contributing factor was inappropriate design of rails and beams fastening, and also insufficient number of rail dilatations. A repair program was proposed which involved the use of additional rail fastenings and dilatations.

1 Introduction

Civil structures in service are subjected to different actions. Depending on their nature, the intensity of actions can vary, which directly translates to the strength utilization of the structural element. Cyclic loading is a special type of actions. It often produces fatigue causing damage to material, which in turn leads to structural failures and collapses. The fatigue phenomenon is of particular significance for engineering objects that have been in operation for many years, such as bridges [1]. Fatigue is accompanied by the cracking phenomenon, which generates high stress concentrations around the discontinuity in the material structure. Fracture is observed in many structural materials, including steels [2-4]. For steel structures, brittle fracture is extremely dangerous [5], thus it is essential to prevent it.

* Corresponding author: kossak@tu.kielce.pl

Impact loads constitute a separate category of actions. They are characterized by high impact energy and short duration. The impact value exceedance of a given limit, i.e. safety limit, leads to extremely dangerous scenarios. Additionally, cyclic fatigue loads and dynamic actions resulting from the operation of mechanical devices, in some cases can cause serious damage to the structure.

2 Supporting structure and the crane runway

The investigations concerned load bearing elements that supported overhead cranes in a warehouse building. The schematic diagram of the building structure, location of the crane beams and the runway are shown in Fig. 1.

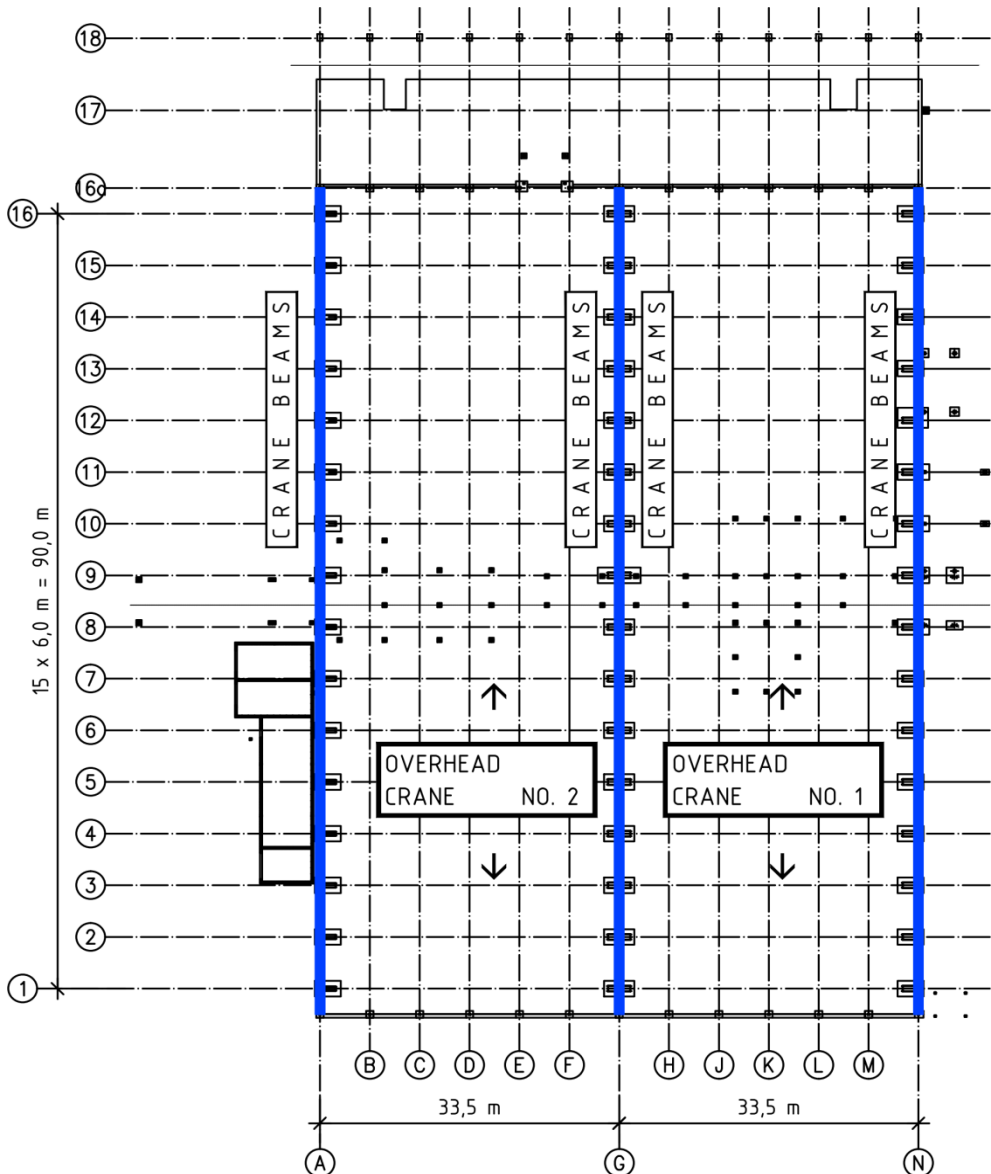

Fig. 1. Schematic diagram of the building structure.

The supporting structure of the cranes has the form of a single-span beam system, stiffened with truss braces. The beams are made of hot-rolled HEA650 steel profiles. Laced built-up columns, with axial spacing of 6 m, are made of IPE600 profiles. The lacing is fabricated from channel bars.

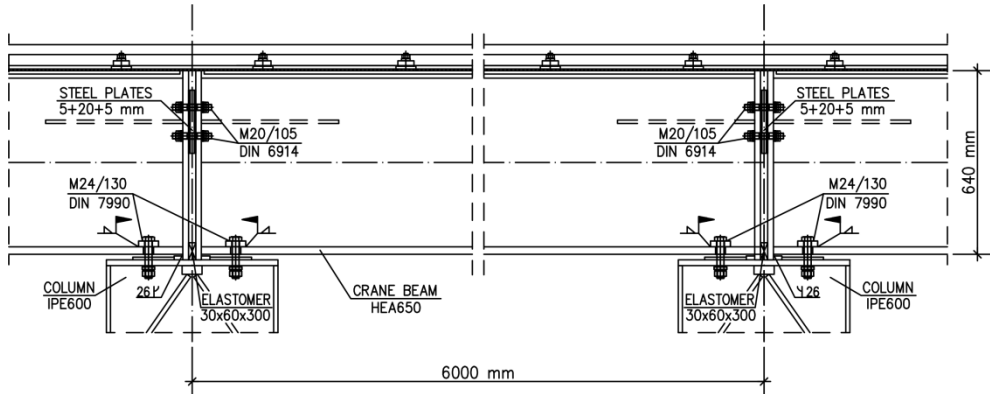

Fig. 2. Design of crane beams and heads of columns.

Crane runways were constructed from A75 steel rails. Those continuous rails were fixed to the upper flange of the crane beam using the Valente fastening system and 8.8 class M16 bolts. In order to compensate loads, the rails were supported on elastomer pads. The runway construction is shown in Fig. 3.

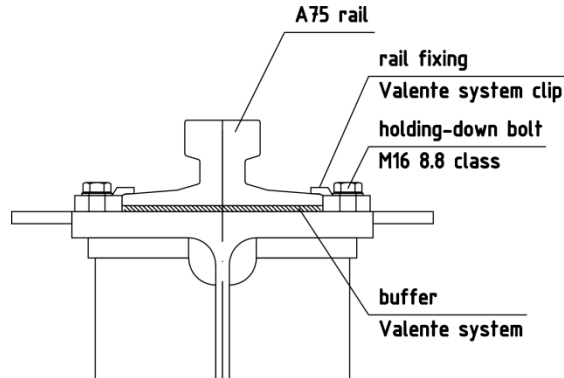

Fig. 3. Elements of the crane runway.

3 Crane runway damages

Damages to crane runways occurred while the building was in service. Two types of damages were identified:

- excessive horizontal and vertical deformation of rails,
- loosening and failure of rail – beam connections.

The runway deformations, i.e. deflections of the rails, were so large that they could be seen, so it was not necessary to take specialist measurements. As a result, during the crane run, wheels hit the side surfaces of the rails, which caused vibrations in the supporting structure.

Exemplary photographs of the runway damages are shown in Fig. 4a (bolt loosening) and 4b (failure of the rail and beam connection).

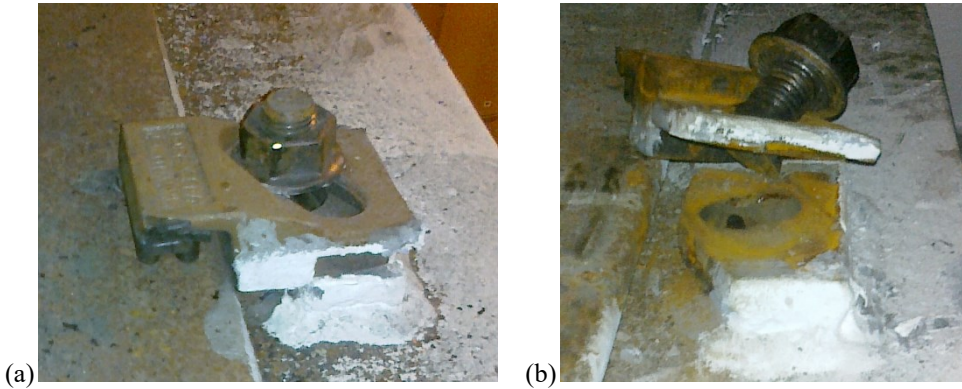

Fig. 4. The view of loosened bolt (a) and damage to the rail fastening to the beam (b).

4 Runway damages survey

Damages to rails fastening (bolts loosening and failure) resulted in increased rail susceptibility to forces generated in crane runs. That especially referred to forces perpendicular to the runway, resulting from inertia and braking forces from loads moved by the cranes.

Consequently, noticeable rail deformation was observed, which reduced the service life of cranes. The first stage of structure condition assessment involved the survey of all the damages found in the runway. For this purpose, control geodetic measurements of the location of characteristic runway points were taken.

4.1 Horizontal deformation of the crane runways

Analysis of geodetic measurements obtained for cranes No. 1 and 2 revealed exceeding the permissible deviations of the rail axial spacing s . According to PN-EN 1090-2:2009P [6], for class 2 and $s = 30.5$ m, the maximum axial spacing deviation is:

$$\Delta s_{\max} = \pm [5 + (s - 16)/4] = \pm [5 + (30.5 - 16)/4] = \pm 8.6 \text{ mm} \quad (1)$$

For crane No. 1, the deviation was exceeded at six points, while for the crane No. 2, at three points. The deviations ranged from -1 to 15 mm with respect to the original spacing $s = 30\,500$ mm (Table 1 and 2).

Additionally, changes in rail horizontal displacements ΔW and rail spacing Δs were analyzed for a period of one year. The comparative geodetic measurements revealed that horizontal displacements of rails increased in the period of concern. That led to changes in their horizontal spacing s (Table 1 and 2, index "0" denotes values identified at the first inspection, while index "1" at the second inspection, after one year).

Table 1. Results of runway deformation measurements for crane No. 1.

Overhead crane 1		G axis			N axis			G-N axes		
Axis	Point	W_0 [mm]	W_1 [mm]	$\Delta W = W_1 - W_0$ [mm]	W_0 [mm]	W_1 [mm]	$\Delta W = W_1 - W_0$ [mm]	s_0 [mm]	s_1 [mm]	$\Delta s = s_1 - s_0$ [mm]
1	1	-11	-13	-2	0	0	0	30 511	30 513	2
2	2	-9	-11	-2	3	2	-1	30 512	30 513	1
3	3	-5	-9	-4	2	0	-2	30 507	30 509	2
4	4	-6	-9	-3	3	-1	-4	30 509	30 508	-1
5	5	-5	-7	-2	2	-1	-3	30 507	30 506	-1
6	6	2	-2	-4	11	8	-3	30 509	30 510	1
7	7	4	-4	-8	12	9	-3	30 508	30 513	5
8	8	2	-5	-7	14	10	-4	30 512	30 515	3
9	9	1	2	1	10	9	-1	30 509	30 507	-2
10	10	-1	0	1	7	7	0	30 508	30 507	-1
11	11	6	8	2	14	11	-3	30 508	30 503	-5
12	12	9	9	0	17	10	-7	30 508	30 501	-7
13	13	8	8	0	14	10	-4	30 506	30 502	-4
14	14	10	10	0	16	15	-1	30 506	30 505	-1
15	15	5	2	-3	8	6	-2	30 503	30 504	1
16	16	-9	-8	1	0	0	0	30 509	30 508	-1

Table 2. Results of runway deformation measurements for crane No. 2.

Overhead crane 2		A axis			G axis			A-G axes		
Axis	Point	W_0 [mm]	W_1 [mm]	$\Delta W = W_1 - W_0$ [mm]	W_0 [mm]	W_1 [mm]	$\Delta W = W_1 - W_0$ [mm]	s_0 [mm]	s_1 [mm]	$\Delta s = s_1 - s_0$ [mm]
1	1	-7	0	7	0	0	0	30 507	30 500	-7
2	2	-7	-4	3	-1	-1	0	30 506	30 503	-3
3	3	-12	-10	2	-4	-5	-1	30 508	30 505	-3
4	4	-5	-3	2	6	6	0	30 511	30 509	-2
5	5	-1	3	4	4	5	1	30 505	30 502	-3
6	6	-6	-4	2	2	-1	-3	30 508	30 503	-5
7	7	-5	-5	0	-2	-4	-2	30 503	30 501	-2
8	8	-4	-5	-1	-3	-6	-3	30 501	30 499	-2
9	9	-9	-6	3	-4	-4	0	30 505	30 502	-3
10	10	-13	-10	3	1	-3	-4	30 514	30 507	-7
11	11	-7	-7	0	4	0	-4	30 511	30 507	-4
12	12	-7	-6	1	11	6	-5	30 518	30 512	-6
13	13	-7	-5	2	4	2	-2	30 511	30 507	-4
14	14	-8	-6	2	3	0	-3	30 511	30 506	-5
15	15	-9	-10	-1	0	-4	-4	30 509	30 506	-3
16	16	-12	-9	3	0	0	0	30 512	30 509	-3

As regards crane No.1, both rails had a tendency to move in the direction of the A axis. Their spacing in the area between axes 1-8 increased, whereas in the area between axes 9 and 16, it decreased.

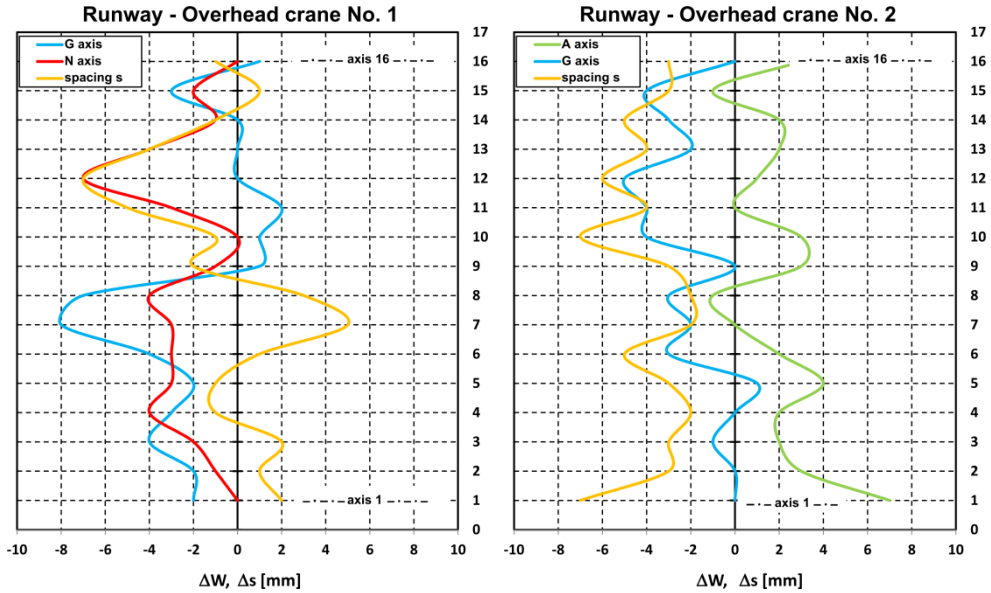

Fig. 5. Changes in crane runway displacements: ΔW – changes in horizontal displacements of rails, Δs – changes in the rail horizontal spacing s .

The rails of crane No. 2 moved in the direction of D axis, i.e. in the direction of crane internal work area. As a result, the rail spacing was reduced.

4.2 Vertical deformation of crane runways

The results of height measurements of No. 1 and No. 2 crane runways indicate that the levels of rail heads in the considered crane operation period changed, i.e. the rails moved vertically. As the data from previous measurements are not available, it was impossible to determine the scope of changes in the period of concern. The only finding is that the alignment of all rails does not meet the requirements of the PN-EN 1090-2:2009P standard [6], due to the exceedance of the permissible deviation for class 2, with the magnitude of misalignment $\Delta = \pm 10$ mm.

5 Analysis of the causes of crane runway damages

The basic factor contributing to runway damages was the fatigue action on overhead cranes produced by cyclic loads. At high speeds of crane runs, up to 120 m/min, and primarily, accelerations related to the load movement and the machine movement (0.3 and 0.6 m/s² for horizontal and vertical movement, respectively), large amount of energy is transferred by overhead cranes to the supporting structure. That has a direct effect on the nature of loads taken by rail connections and beams, which are cyclically loaded with impact forces. Taking into account high stiffness of the crane beams in the horizontal direction, the entire impact energy is first absorbed by rails and fasteners. An important factor is that rails were rigidly welded into one continuous length. Consequently, forces are transmitted to full length of rails. That results in partial transmission of forces to the adjacent crane beams. In this way, the runway is deformed along its entire length. The effect can be minimized by means of rail dilatation. Then, rails work independently of each other and have the possibility of sliding at the ends. To a certain extent, this allows the reduction of elastic deflections after the impacts stop.

The effect of the imperfections of crane runways, i.e. exceedance of permissible horizontal and vertical rail displacements, described in detail in the previous sections, cannot be disregarded. The wheels of cranes traveling at substantial speeds and accelerations need to overcome the resistance of the side surface of the rail heads. The spacing of those beyond the permissible value causes deformation of the runway. Consequently, the rails are loaded by additional horizontal forces. Very high overrunning speeds of cranes also produce vibrations in the supporting structure.

In summary, it was found that the applied system of the runway fixing does not fulfill its function, and the current technical condition of rail connections to girder beams is bad. Consequently, repairs are required.

6 Recommendations

Based on the analysis of the inspection results, it was found that during the service period of concern rail horizontal displacements occurred, which resulted in changes in rail spacing. Vertical rail arrangement does not meet the normative requirements, and the solutions adopted for rail fastening do not guarantee the correct operation of cranes. In a few cases, damage was found, namely broken bolts and loosening of rail fastenings to crane girders.

Considering the issues mentioned above, it was proposed to reconstruct the rail connections to beams according to the following guidelines:

- dividing each rail with two dilations, by cutting them at an angle of 45° (in accordance with the recommendations of PN-EN 1993-6:2009P [7]),
- levelling, straightening and horizontal positioning of rails,
- repair of rail fastenings to crane girders (replacement of broken bolts),
- strengthening of rail fastenings to the crane beams by making additional fastenings, using bolts to connect rails and crane beams.

The above structural changes are shown in Figs. 6 and 7.

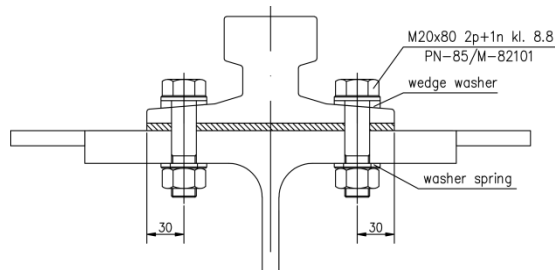

Fig. 6. Additional fastening of rails.

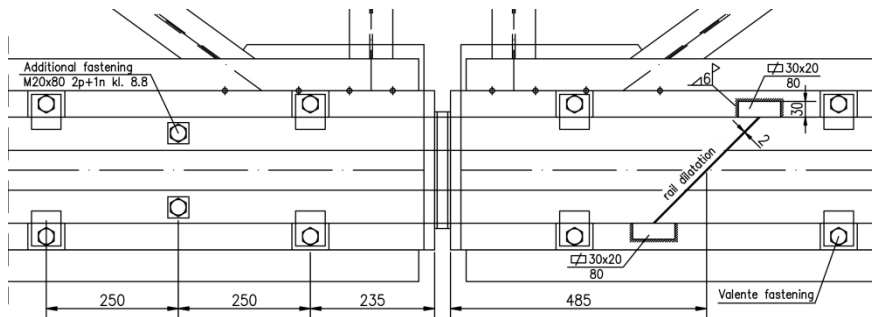

Fig. 7. Additional dilatation of rails.

7 Summary and conclusions

Due to the character of crane operation, the elements of crane support structures are subjected to loads, which may cause damage. This refers to both crane beams and runway elements, i.e. rails with fixing elements. In non-typical situations, when fatigue-related effects of machines (cranes) operating at high speeds and accelerations occur, substantial dynamic interactions and impact loads may be observed. All these factors should be taken into account at the design stage, because, as can be seen from the analysis of the case reported in the paper, they can lead to damage to the support structures, which makes it impossible to operate the cranes.

References

1. P. G. Kossakowski, *Balt. J. Road. Bridge. E.*, **8**, pp. 166-173 (2013)
2. G. Vukelic, J. Brnic, *Int. J. Appl. Mech.*, **9**, 11 (2017)
3. P. G. Kossakowski, *J. Theor. App. Mech.-Pol.*, **52**, pp. 995-1006 (2014)
4. P. G. Kossakowski, *Pol. Marit. Res.*, **21**, pp. 100-107 (2014)
5. G. M. Boyd, *Brittle Fracture in Steel Structures* (Elsevier, 2016)
6. PN-EN 1090-2:2009P Execution of steel structures and aluminium structures - Part 2: Technical requirements for steel structures
7. PN-EN 1993-6:2009P Eurocode 3 - Design of steel structures - Part 6: Crane supporting structures