

# Influence of selected cycle components parameters on the supercritical CO<sub>2</sub> power unit performance

Marcin Wołowicz\*, Jarosław Milewski, and Gabriel Ziembicki

Institute of Heat Engineering, Warsaw University of Technology, Nowowiejska 21 Street 00-665 Warsaw, Poland

**Abstract.** The paper presents the influence of selected components parameters on the performance of supercritical carbon dioxide power unit. For this analysis mathematical model of supercritical recompression Brayton cycle was created. The analysis took into consideration changes in the net cycle power and efficiency for different compressor inlet temperatures. The results were obtained for a fixed minimum pressure of 7.4 MPa and fixed recompression split ratio. The studies conducted in this paper included also consideration of sensitivity of the cycle efficiency to a change in recuperators heat transfer area. In order to determine how each recuperator influences the cycle performance, an analysis of efficiency dependence on the recuperators area was made. Another parameters that were investigated are to a change in turbine and compressors isentropic efficiency and their influence on the cycle efficiency. In the reference cycle, isentropic efficiencies were set up as 88% for both the main and recompression compressor, and 90% for the turbine. Since isentropic efficiency is a sort of measure of broadly defined quality of a turbine or compressor, including airfoil shape, sealing, etc., it may be a significant cost factor that should be considered during cycle design. Therefore, a sensitivity analysis of cycle efficiency to both compressors and turbine isentropic efficiencies was conducted.

## 1 Introduction

In the 1960s, Feher [1] studied various gases' properties for a purpose of finding the most suitable one for a supercritical thermodynamic cycle. Carbon dioxide was proposed as a working fluid due to several reasons. First, its physical properties e.g. critical pressure, which is significantly lower compared to water, allows lower operating pressure. Then, CO<sub>2</sub> thermodynamic and transport properties are well known, hence cycle analysis is based on reasonably firm data. Finally, carbon dioxide is abundant, non-toxic and has relatively low cost. The analysis proved that CO<sub>2</sub> supercritical cycle offers several desirable features as high thermal efficiency (the investigated cycle reached a thermal efficiency of 55% under ideal conditions), low volume to power ratio and no blade corrosion and cavitation.

## 2 Supercritical CO<sub>2</sub> cycles

The most basic and compact supercritical CO<sub>2</sub> cycle is a simple Brayton cycle. It is simple and offers relatively good efficiency. However, there is still potential to improve its performance. The biggest reduction in efficiency of the supercritical Brayton cycle comes from the large irreversibility in the recuperator [2]. So called compound cycles can overcome this problem and can perform significantly better than the regular supercritical Brayton cycles.

Supercritical CO<sub>2</sub> cycles can be divided in three groups: pre-compression cycles, partial cooling cycles and recompression cycles.

The pre-compression Brayton cycle is one of the ways to increase the generation within the cycle and reduce the pinch-point problem. As shown in Fig. 1 the cycle is similar to normal Brayton cycle with a small modification.

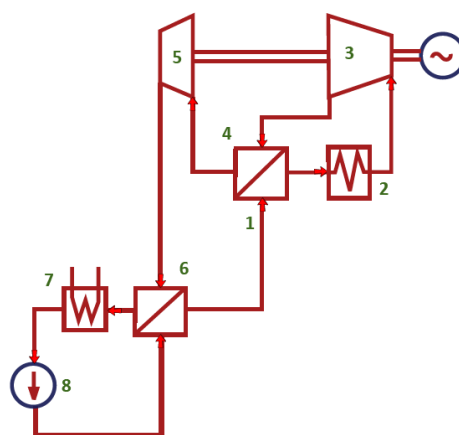

Fig. 1. Schematic of the pre-compression Brayton cycle [2].

First, the working fluid is compressed and then heated in the high temperature recuperator (1) using exhaust heat from the turbine. The fluid passes to a heat source (2) where the heat is added and then expands in the turbine

\* Corresponding author: [marcin.wolowicz@itc.pw.edu.pl](mailto:marcin.wolowicz@itc.pw.edu.pl)

(3). The remaining exhaust heat is extracted from the fluid in the high temperature recuperator (1). The difference from the normal Brayton cycle is that in the middle of recuperation process, when the hot fluid temperature approaches to the heated fluid temperature, a compressor (5) is introduced that compresses the fluid to higher pressure. As the fluid pressure rises, so does its temperature and specific heat. Thus, regeneration process can continue and more available heat is returned to the heated fluid. This extra heat reduces average temperature at which heat is rejected from the cycle and increases the average temperature at which heat is added to the cycle. This results in an efficiency improvement of 6% over a Brayton cycle that would otherwise suffer from the pinch point problem [3].

Another cycle layout that aims at reducing Brayton cycle drawbacks is the partial cooling cycle presented in Fig. 2. In general, its operation differs from the previously described cycle by two adjustments. The first is that only a fraction of the working fluid is compressed in the low temperature compressor (pump). The rest is compressed in the recompression compressor that is introduced before the pre-cooler and after the pre-compression compressor. The second difference is the introduction of another pre-cooler before the pre-compression compressor. This way, similar to the pre-compression cycle, more heat is available for the regeneration process.

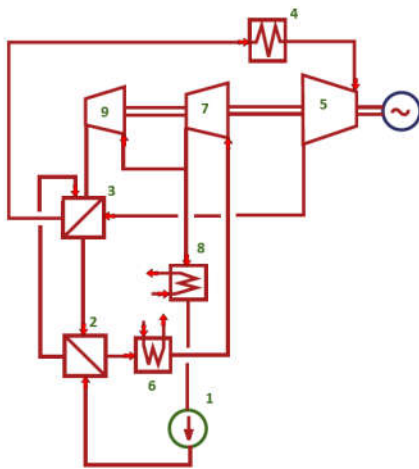

**Fig. 2.** Schematic of the partial cooling Brayton cycle [2].

After compression in the main compressor (1), a fraction of the working fluid is heated in the low temperature recuperator (2) and merged with the flow from the recompressing compressors that is at the same conditions. The fluid is then heated in the high temperature recuperator (3) and in the heat source (4) in turn and then enters the turbine (5). After the expansion process the fluid returns its heat in the high and low temperature recuperator (2,3). Then it passes to the pre-cooler (6) where it is cooled to the pre-compressor inlet temperature, and subsequently compressed in the pre-compressor (7). A part of the pre-compressed fluid is sent to the pre-cooler (8) and the main compressor. The rest is recompressed in the second recompressing

compressor (9) to the high temperature recuperator inlet conditions, and then is merged with the stream from the main compressor. This move eliminates the pinch point problem, since due to the lower mass flow rate on the high pressure side of the low temperature recuperator, the mass flow weighted heat capacity of the streams is about equal and a pinch point does not occur.

The cycle improves its efficiency by reducing the average temperature of heat rejection so that the efficiency improvement is bigger than that for the pre-compression cycle.

Although the partial cooling cycle seems to be attractive due to its efficiency benefits, the complication of a cycle layout may prove detrimental to the economic. Therefore, another cycle is introduced, a recompression cycle, which is simpler than both partial cooling and pre-compression cycle. The general layout of the cycle is shown in Fig. 3.

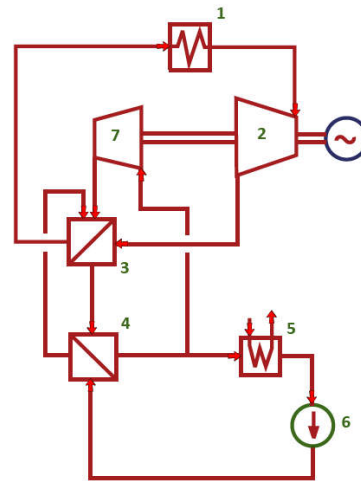

**Fig. 3.** Schematic of the recompression Brayton cycle [2].

The advantage of this cycle is that it completely eliminates one pre-cooler and pre-compressing compressor from the cycle. After the regeneration process in the high temperature recuperator (3) the fluid is heated in the heat source (1) and passes to the turbine (2). Then it enters successively the high and low temperature recuperators (3,4) and returns its heat to the fluid at the high pressure side. The fluid flow is then split into two streams. The first is sent directly to the recompression compressor, where it is compressed to the same pressure conditions as the CO<sub>2</sub> leaving the main compressor and merged with it in the high pressure recuperator. The second flow is cooled in the pre-cooler (5), compressed in the main compressor (6) and heated in the recuperators.

The effect of recompression is sufficient to overcome a pinch point problem. Owing to the decreased mass flow rate at the high pressure side of the low temperature recuperator, the mass flow weighted heat capacity of the streams is about equal at both sides and a pinch point does not occur. The recompression cycle is, along with the pre-compression cycle, the simplest among the surveyed cycles. In addition, at the desired operating conditions of turbine inlet pressure and temperature (20

MPa and 550°C), it proves to achieve the highest efficiency of all examined cycles [2, 4].

### 3 Model description

The supercritical CO<sub>2</sub> Brayton power cycle with recompression was selected for further examination due to its relatively high power conversion efficiency compared to other cycle layouts proposed in literature. In this cycle configuration a portion of CO<sub>2</sub> flow is recompressed without rejection of heat. Splitting the flow allows to compensate for the difference between specific heats of the high and low pressure CO<sub>2</sub> flows in the low temperature recuperator.

The cycle evaluation was performed by using the GateCycle application. The design of the cycle assumes a supercritical CO<sub>2</sub> inlet flow with a given parameters, which is generated by a generic heat source. The CO<sub>2</sub> is expanded through the turbine to produce electric power. The flow at a lower temperature and pressure then passes through high and low temperature recuperators successively, where it is further cooled. Then, the flow is split into two streams. One stream is cooled down in the cooler that provides additional cooling to the fluid before it enters the main compressor. The second stream after being split is compressed in the recompression compressor and then mixed with the first flow which has similar state in terms of pressure and temperature. The merged stream passes to the high temperature recuperator, where the heat is recovered and then returns to the heat source.

As a first step of analysis, a reference cycle was developed to be used as a basis for further examination. Realistic component operating conditions and design parameters were selected to be consistent with real case application. The reference cycle assumes a heat source which is able to generate constant CO<sub>2</sub> flow at temperature of 550°C and mass flow rate of 10,000 t/h. At the bottom of the cycle the flow temperature and pressure are 31.25°C and 7.4 MPa and are very close, but still slightly above the CO<sub>2</sub> critical point (30.98°C and 7.373 MPa). The split ratio is initially assumed as 0.28, which means that this part of the flow is sent directly to the recompression compressor without being cooled before to the lowest cycle temperature. Besides the main parameters values, the following assumptions have been made:

1. the system operates at steady state conditions,
2. expansion and compression processes are adiabatic but non-isentropic,
3. appropriate isentropic efficiencies were employed for both turbine and compressor,
4. effectiveness for heat exchangers are used for low and high temperature recuperators,
5. pressure drops due to friction in all the heat exchangers and pipelines are negligibly small,
6. changes in kinetic and potential energies in each component are negligible.

### 4 Obtained model analysis

#### 4.1 Compressor inlet temperature

Fig. 4 shows changes in the net cycle power and efficiency for different compressor inlet temperatures.

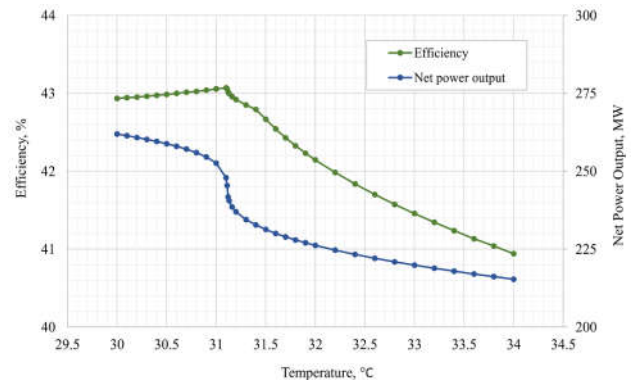

**Fig. 4.** Efficiency and net power output for different compressor inlet temperatures (fixed split flow ratio).

The results were obtained for a fixed minimum pressure of 7.4 MPa and fixed recompression split ratio. A rapid variation in both cycle net power and efficiency can be seen in the near critical region, when carbon dioxide moves from supercritical gas state to supercritical liquid state passing through the peak in specific heat capacity rate observable in the critical or pseudocritical point. Compressor inlet temperature exhibits the optimum point at the value of critical temperature where the efficiency is maximum. For temperature of 31.1°C efficiency reaches the maximum value of 43.08%, which is about 0.2 percentage points more than efficiency of the reference cycle, where compressor inlet temperature is 31.25°C. However, the magnitude of efficiency gain may not be sufficient in the face of increased cooler duty. Due to the peak in specific heat capacity rate in the critical temperature, required cooler area necessary to cool the working fluid to temperature of 31.1°C is about 11% higher than that in the reference cycle.

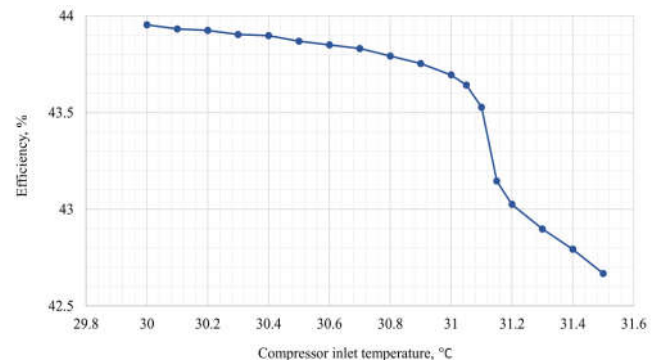

**Fig. 5.** Cycle efficiency as a function of compressor inlet temperature (split flow ratio dynamically optimized for each temperature).

One may consider the existence of efficiency peak and decrease along with decreasing minimal cycle temperature somewhat odd in the light of widely known thermodynamic dependencies that predict higher

efficiencies for lower temperature of heat removal. The correlation, however, does not violate thermodynamic laws - lower efficiency for lower temperature results from absence of the optimization of parameters, whose optimum values depend on compressor inlet temperature.

In the examined cycle, recompression split flow ratio is the parameter which plays a crucial role in the observed phenomenon. Fig. 5 shows efficiency dependence on minimal cycle temperature when the condition of optimum split ratio is satisfied. The graph was obtained by plotting efficiency lines for various recompression split flow ratios at different temperatures levels shown in Fig. 6. Then the maximum efficiency points for each temperature level were collected and illustrated in the graph as a variable dependent on temperature. The shape of efficiency curve presented in Fig. 5 looks more realistic - the abrupt surge is still present, but then, as the temperature decreases, so does the efficiency, which results mainly from decrease in compressor work.

An optimum point for net cycle power does not exist. As the temperature of CO<sub>2</sub> before the compressor declines, the compression work is also reduced, what leads to the higher net cycle power.

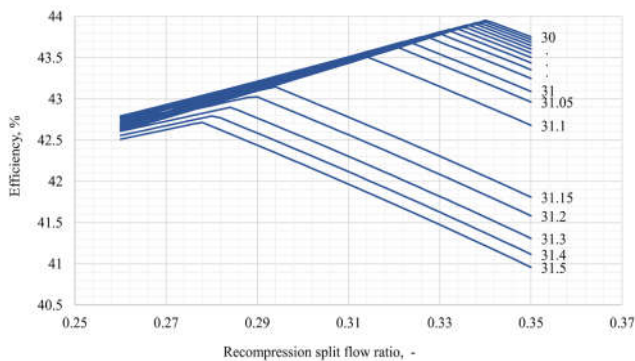

**Fig. 6.** Optimum recompression split flow ratio for compressor inlet temperatures ranging from 30°C to 31.5°C.

#### 4.2 Heat exchangers area

In order to determine how each recuperator influences the cycle performance, an analysis of efficiency dependence on the recuperators area was made. Cycle efficiency was calculated for both recuperators area varying independently of each other from -50% to 50% of its initial value. In the reference cycle recuperators effectiveness was set to 90%, which translates into heat transfer area of 612,363 m<sup>2</sup> and 482,667 m<sup>2</sup> for the low temperature and high temperature recuperators respectively.

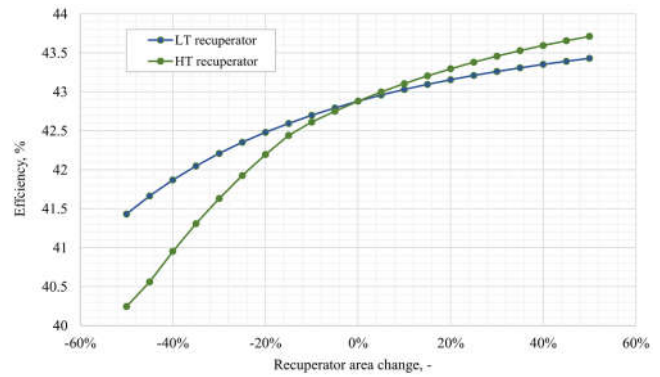

**Fig. 7.** Sensitivity of the cycle efficiency to a change in recuperators heat transfer area.

As shown in Fig. 7, the rule that the cycle efficiency grows when recuperator area is increased and falls when recuperator area is reduced applies to both recuperators. However, the efficiency line for high temperature recuperator is steeper, which means that it is easier to obtain efficiency change manipulating high temperature recuperator area.

The general tendency revealed by Fig. 7 can be explained by broader dependence between efficiency and recuperation level in the supercritical CO<sub>2</sub> cycle. As the recuperator area increases, more heat can be transferred and more heat can be return to the cold fluid. Thus, less heat is lost in the cooler and less heat has to be supplied to the cycle by a heat source. As a result the ratio of net cycle power to added heat, which is in fact the cycle efficiency, increases.

#### 4.3 Turbine and compressors isentropic efficiency

In the reference cycle, isentropic efficiencies were set up as 88% for both the main and recompression compressor, and 90% for the turbine. Since isentropic efficiency is a sort of measure of broadly defined quality of a turbine or compressor, including airfoil shape, sealings, etc., it may be a significant cost factor that should be considered during cycle design. Therefore, a sensitivity analysis of cycle efficiency to both compressors and turbine isentropic efficiencies was conducted. In order to present and compare how turbine and compressor quality influences the cycle performance, isentropic efficiency of these devices was changed independently in the range from 78% to 95%.

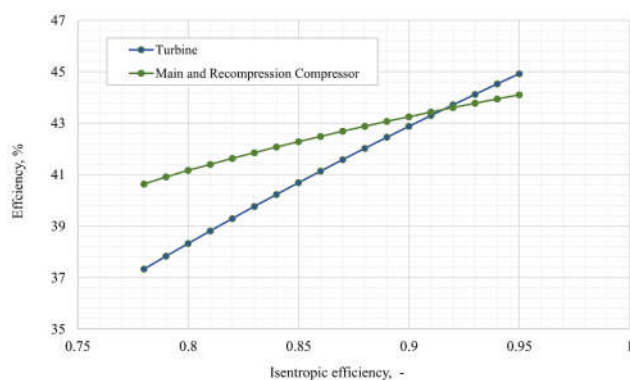

**Fig. 8.** Sensitivity of the cycle efficiency to a change in turbine and compressors isentropic efficiency.

Calculated efficiency lines are presented in Fig 8. Since both main compressor and recompression compressor are used to realize the same process, their efficiencies were changed simultaneously and are presented by the continuous green line. Thus, the slopes of both lines can be used to determine which process (compression or expanding) has more impact on the recompression cycle. A significant difference occurs between these two processes in case of compression, 1 percentage point change in isentropic efficiency change translates into slightly more than 0.2 percentage points of net cycle efficiency, whereas for expanding process the change of net efficiency is almost 0.45 percentage points.

## 5 Conclusions

Due to a strong influence of the compressor inlet temperature on optimal recompression split flow ratio, these parameters were altered and optimized simultaneously to mitigate a distortion of efficiency curve. Optimization of the minimal cycle temperature is a good example of such distortion. For a fixed recompression ratio, decrease in the compressor inlet temperature in the area under the critical point causes fall in efficiency, which may seem unnatural. The results obtained when recompression ratio was dynamically optimized for each temperature level indicate that the cycle efficiency rises along with decreasing compressor inlet temperature above and under the critical point as well. There is an abrupt efficiency surge of about 0.7 percentage points in the near critical region caused by sudden fall of compression work. However, similar rise also occurs in the cooler heat transfer area, because of increased amount of heat that has to be removed from the cycle. This fact may be a deciding factor in choosing the lowest cycle temperature, which, considering additional cost of the cooler, probably should be set as close as possible to the critical temperature.

For the reference cycle the optimum recompression split flow ratio is 0.28, which means that this part of the flow is recompressed without being cooled before to the minimum cycle temperature. However, increase in recompression rate always demands more heat transfer area to satisfy assumed heat exchanger effectiveness, therefore an optimum split flow ratio should be a trade-

off between efficiency gain and additional capital cost. During design and optimization of a specific system, it is crucial to take into consideration that recompression flow ratio is very sensitive to other cycle parameters, in particular compressor inlet temperature. For instance, for temperature range from 30°C to 31.5°C, the recompression ratio that guarantees the highest efficiency varies from 0.28 to 0.34.

Since achieving a given isentropic efficiency in two different machines as compressor and turbine is not of the same level of difficulty, and their isentropic efficiencies influence overall net cycle efficiency differently, it is possible that shifting the effort of efficient design from one device to another may be more effective in terms of cost and performance.

## Acknowledgements

This scientific work was financially supported as a research project number 2015/19/D/ST8/02780 by the National Science Centre, Poland

## References

1. E. Feher, *Energy Conversion* **8**, pp. 85-90 (1968)
2. V. Dostal, M.J. Driscoll, P. Hejzar, *A Supercritical Carbon Dioxide Cycle for Next Generation Nuclear Reactors, Advanced Nuclear Power Technology Program*, (Thesis (Sc. D.) - Massachusetts Institute of Technology, 2004)
3. G. Angelino, 1968, ASME Paper No. **68-GT-23** (1968)
4. M. Kulhánek, V. Dostál, *Thermodynamic Analysis and Comparison of Supercritical Carbon Dioxide Cycles, Supercritical CO<sub>2</sub> Power Cycle Symposium*, pp. 1 – 7 (2011)