

Analysis of a Dry-type Reactor Fault Based on COMSOL Thermal Field Simulation and High Frequency Pulse Oscillations

LUO Xin, WANG Shuai-yi, WANG Yao, GU Yu

Guangzhou Bureau, CSG EHV Power Transmission Company, Guangzhou 510663, China

Abstract. For a single-phase earth fault of 35 kV dry-type reactor, the 5th package area is found with serious turn-to-turn short circuit after it conducts the DC resistance test, turn-to-turn insulation test of high frequency oscillation pulse and rework disassembly. The turn-to-turn short circuit of resistance will lead to wire fusing, which makes the conventional pre-test projects have limitations. With COMSOL finite element thermal field simulation of the fault 35kV dry-type reactor, the temperature distribution result of the reactor indicates that the hottest point is at the 6th package during the reactor operation and the temperature rises 73.75K. In addition, the temperature rises of the 5th, 7th, 14th, 15th package is also higher than other packages, which easily causes device failure due to insulation deterioration. Through the analysis and thermal field simulation of the test for failed reactor, it can provide the reference basis for equipment design, manufacture, daily repair and maintenance.

1 INTRODUCTION

The reactor is a critical SVC device in power system, which plays an important role in the power transport with its excellent electrical performance. The dry-type air-core reactor develops rapidly recently and has replaced the traditional oil immersed iron core reactor gradually. It features simple installation, light weight, easy maintenance without fire risk, growing a wide market for its application in the power system [1-3].

During reactor's operation, it's easy to cause partial turn-to-turn insulation, resulting in reactor burnout finally. According to statistics, above 90% of the reactor fault and burnout are resulted from the turn-to-turn insulation defect [4-6]. The turn-to-turn insulation fault of dry-type reactor is gradually developed by insulation defect during design and manufacture. Before it develops to a certain degree, it's hard to be detected by traditional preventive tests, such as DC resistance test, impedance test, infrared detection, and other means.

The dissected results of several dry-type reactors show that turn-to-turn insulation faults often occur in the tundish closure, where the temperature rise is generally the highest, and the insulation weak points are most easily deteriorated. Therefore, it is of great significance to study the thermal field distribution characteristics of the dry reactor.

2 BRIEF INTRODUCTION OF REACTOR FAULT

35kV 334 parallel dry-type reactor tripped out suddenly at 500kV Huadu substation on May 9th, 2017. The fault is shown as Fig.1. It was found that there were signs of burns inside the reactor bottom, and there's no abnormality found in conventional pre-tests of the DC resistance on site. The test result is as shown in Table 1. As to make sure the reactor failure, the tester conducted the high-frequency impulse oscillating turn-to-turn insulation test for the 334 reactor on May 17th, and the result showed that there's serious turn-to-turn insulation fault in A phase of the 334 reactor. From Table 2, it can be seen that the measured value of DC resistance is larger than the pre-test value in 2017. In the contrary, it gets closer to the factory default (the dissected result shows it is caused by the external wire burnout due to turn-to-turn insulation fault, which also manifested the limitation of DC resistance test when the turn-to-turn insulation fails.

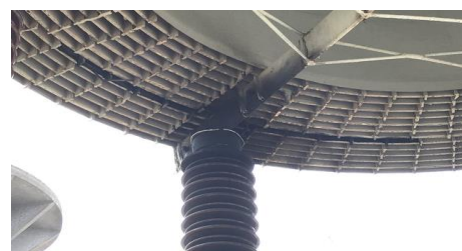

*Email: luoxin121589@126.com

Fig1. The black mark of A phase support insulator

Tab1. Dc resistance test results

phase Time	A Phase	
	Test Value	Deviated from Default (%)
Default Value	0.03557	--
Transfer Value 2017	0.03556	-0.03
Measured Value	0.03521	-1.02
	0.03563	0.17

3 HIGH-FREQUENCY IMPULSE OSCILLATING TURN-TO-TURN INSULATION TEST

The principle of high frequency pulse oscillation test has been discussed by literature [7, 8] in details, which will be no longer described here. The turn-to-turn insulation test of 35kV 334 dry-type reactor in Huadu station has been fully illustrated as below.

3.1 Test Result

The turn-to-turn insulation of the 334 reactor is tested by the high frequency impulse oscillations, and the three-phase waveform is shown as Fig.2. The red curve is the nominal voltage (20% test voltage), and the blue curve is the full voltage.

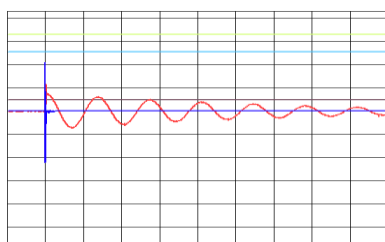

(1) 334 A phase waveform

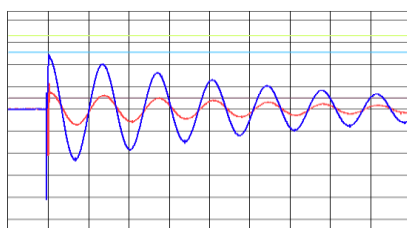

(2) 334 B phase waveform

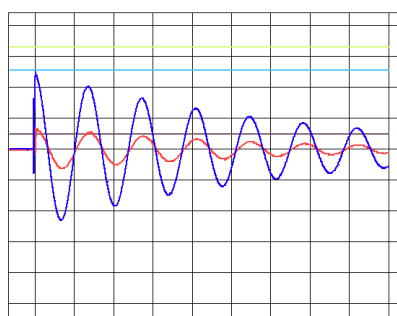

(3) 334 C phase waveform

Fig 2. Waveforms of 334 dry type reactor

During the test, the voltage crossing waveform of the reactor is the oscillatory waves, and the oscillation frequency is the function of sample inductance and charging capacitor, so voltage waveform amplitudes under normal reactor nominal voltage and full voltage are different but in sample frequency or the peaks and troughs and zero crossing points should be rejoined.

During pressure rising of phase A, there is no oscillating wave on the oscilloscope, as shown in Fig. 2(1), and it is mainly because that the device has serious turn-to-turn short circuit. The defective part is discharging all the time that results in abnormal charging of the loop charging capacitor, which can't form the attenuation damped oscillation. The waveform frequencies of B and C are consistent under the nominal voltage and full voltage that perfectly match the zero-crossing point, conforming to typical waveform characteristics of turn-to-turn insulation test for normal reactors.

4 RETURN FOR DISSECTION

It is found through the appearance test of the reactor that there are many black substances between the 5th and 6th package, which is the fault point layer by primarily judgment. Therefore, open the housing and each package one by one for the checking.

Open the first 4 layers of the package from outside to inside, it is observed that there're a few of black ablative marks inside, but the winding aluminum wire and insulating material of main body are in good condition, and there's no obvious deformation and damage in internal structure. Cut the 6th package further, the inside part of the cut part is covered with the black burning substance. There's an aluminum conductor fusing area from the 1/4 height above the package bottom to the top, as Fig. 3, which can be concluded that the 5th package should be the reactor fault area, and 6th package without wire fusing phenomenon, so it won't disassemble the 6th package no more.



(1) 5th package



(2) Package Inner Side

Fig3. Disassembly of reactor

5 FAULT REASON ANALYSIS

5.1 Finite element simulation of dry-type reactor's temperature field

In this paper, the COMSOL simulation software is used to calculate the temperature field distribution of dry-type reactor, so as to analyze the cause of failure. The calculation includes the heat source of reactor, establishments of simulation mathematical model and simulation physical model for the reactor temperature field, and settings of calculation boundary conditions for the reactor temperature field and material parameters for the reactor [9-12].

5.2 Calculation Result of Dry-type Reactor Temperature Field

5.2.1 Heat source calculation result

After calculation, the maximum volume on each package is 0.2867m², and the minimum volume on each package is 0.1152 m². The maximum heat source density of each package in reactor is 21208.41W·m⁻³. Each package corresponding heat source density is as Tab. 4. Among which, names of reactors from the reactor outside to inside on the 1th ~16th packages.

Tab2. Equivalent volume heat source density

Package	Heat source density (W·m ⁻³)	Package	Heat source density (W·m ⁻³)
16	21208.41	8	12070.23
15	17030.53	7	18243.28
14	15126.34	6	18104.60
13	13695.78	5	17982.90
12	13967.70	4	18593.98
11	12877.63	3	18901.79
10	12150.41	2	18916.77
9	12625.35	1	19918.39

5.2.2 Calculation result of reactor temperature field

After setting boundary conditions and heat source loading, process heat flow coupling calculation of the reactor and the obtained temperature field distribution of reactor is as shown in Fig.4.

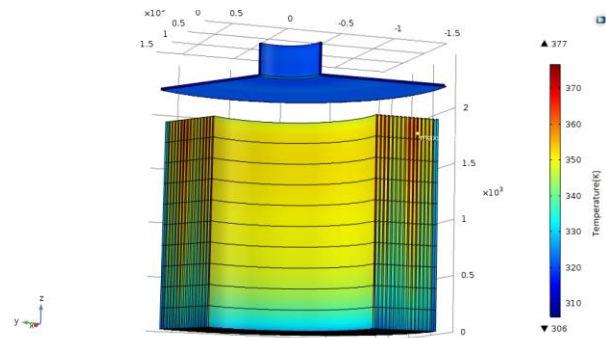

Fig4. The temperature field distribution of the reactor

From calculation result of the temperature field distribution of reactor in Fig.4, it can be seen that the maximum temperature of the whole reactor is 376.9K, the highest temperature is on the 6th package (from the outside of reactor to the inside) at 90% height from the bottom, and the temperature rise at the highest temperature point is 73.75K. From the distribution of heat source density, the heat source density at the 16th package is maximum, but its temperature rise isn't the largest, which is because that the natural convection heat dissipation condition on external surface of the 6th package is good, and the air flow will take away some of the heat to reduce the temperature. The heat source density on the 6th package isn't the largest, but it is larger than other layers, and the heat source densities on the 7th and 5th packages. In addition, the 6th package is at the middle of each package in the reactor, so the heat dissipation is poor, and temperature is highest. Except for the 6th package, the temperature rises high on the 15th, 14th, 7th and 5th packages. From the axial direction, the axial temperature distribution of each package has following rule: the upper temperature of each package is the highest; the middle temperature is the next, while the lower temperature is the lowest.

5.2.3 Calculation result of reactor flow field

The obtained flow field distribution of reactor is as shown in Fig.5.

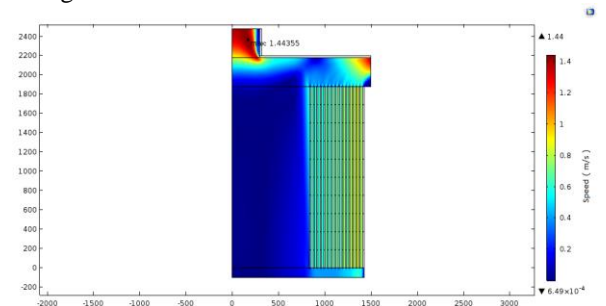

Fig5. Distribution of reactor flow field

From the reactor flow field distribution in Fig.5, we can see that the maximum velocity field inside whole reactor is near the air outlet of rain cover at the top of the reactor, and the velocity field between each package is generally within 0.6-1m/s that is relatively large, which

indicates that the natural convection exists between each package during reactor operation. Between the packages, airflow rates between the 1th and 2th, 2th and 3th, 3th and 4th layers are larger than other packages, and air natural convection cooling takes part of the heat away. Therefore, the heat source densities of the 4th, 3th and 2th layers are higher than the 5th layer, but the temperatures of these three packages are lower than the 5th package.

5.2.4 Analysis of reactor fault cause and maintenance suggestion

From temperature field distribution, the hot spot temperature rise of reactor under rated current is at 90% height from the bottom on the 6th package, and package temperatures on the 5th, 7th, 14th and 15th layer also rise largely. The short circuit of fault reactor in this case is right at the middle and upper part of the 5th layer, which is one of the points with highest temperature rise. Combined with the disassembly situation, it can be seen from the analysis that:

After long-term operation, the weak point of internal insulation gradually deteriorates on the package with large temperature rise that eventually results in one part between a pair of paralleling wires on the 5th package breakdown, forming internal circulation, which easily causes further deterioration breakdown near the insulation layer to form large range circulation.

The starting point of the reactor should at the top area, and the area of short circuit develops from the top to bottom that results in aluminum conductor fusing, which stops when it develops to 1/4 height from the bottom. The single-phase grounding fault of reactor on field is resulted by the discharge channel formed after large amount of ablative residue dropping on the post insulator.

During the routine maintenance of reactors, the maintenance should be strengthened on the 5th, 6th, 7th, 14th and 15th package. When manufacturing the equipment, special attention must be paid to the insulation process of the above packages to avoid insulation defects.

6 CONCLUSION

Through the DC resistance pre-test, turn-to-turn insulation test of high frequency oscillation pulse, rework disassembly and COMSOL finite element thermal field simulation for the 334 paralleling reactor with single-phase earth connection fault in Huadu station, the following conclusions can be drawn:

Conventional pre-test projects have limitations on the presence of the turn-to-turn insulation fault. The high frequency pulse oscillation shows the A phase of 334 reactor has serious turn-to-turn insulation fault, resulting in internal conductor burning. The DC resistance is closer to the factory value compared to the pre-test value of 2017.

After high frequency pulse oscillation test and rework disassembly, the fault point of the reactor is the serious turn-to-turn fault on the 5th package and has wire fusing.

From the calculation result of COMSOL temperature field, it can be seen that during reactor operation, the hotspot temperature rise is at the 90% height from the bottom on the 6th package, the hotspot temperature rise is 73.75K, and the temperature rises of the 5th, 7th, 14th and 15th are also high. Looking from the package's axial direction, the temperature distribution rule of each package is that the upper temperature of each package is the highest, the middle temperature is the next, while the lower temperature is the lowest.

Conduct thermal field simulation for dry-type reactor based on COMSOL finite element simulation, it can be found that the hot spot of reactor during operation, providing reference basis for the design, manufacture, daily check and maintenance for the reactor.

REFERENCE

1. XU Linfeng. Fault analysis of dry-type air-core series reactor [J]. Power Capacitor & Reactive Power Compensation, 2008, 29 (2):50-54.
2. PAN Zhen, WEN Dingyun, YANG Ping, et al. Application of Pulse Voltage Resonance Method to the Detection of Inter-turn Insulation of Dry-type Reactor[J]. Power Capacitor & Reactive Power Compensation, 2015, 36 (5):88-91.
3. FU Weiping, ZHAO Jingwu, HUO Chunyan. Reason analysis for a 35k V dry type reactor fault[J]. Power Capacitor & Reactive Power Compensation, 2011, 32(1):59-62.
4. XIA Changgen. 35 k V together of dry type hollow shunt reactor failure analysis[J]. Power Capacitor & Reactive Power Compensation, 2009 (5): 43-45.
5. Operation and Maintenance Department of SGCC. The casebook for typical failure on transformers [M]. Beijing, China: China Electric Power Press, 2012: 120-144.
6. JI Juan, YU Jihui, YUAN Yifei, et al. Hollow reactor magnetic field distribution and the guarded body erect study[J]. High Voltage Apparatus, 2009 (6) :61-64.
7. LIAO Minfu, CHENG Xian, ZHAI Yunfei. Simulation and Experiment on Impulse Oscillating Turn-to-turn Insulation Test System of Dry-type Air Core Reactor [J]. High Voltage Engineering, 2011, 37(6): 1343-1348.
8. XU Linfeng, LIN Yifeng, WANG Yonghong, et al. Technique research on turn -to -turn overvoltage test for dry-type air-core reactors[J]. High Voltage Apparatus, 2012, 48 (7): 71-75.
9. CHEN Rong, YANG Songwei, CHENG Yong, et al. Electromagnetic-fluid-temperature Coupling Calculation and Analysis of Dry-type Air-core Shunt Reactor [J]. High Voltage Engineering, 2017, 43 (9): 3021-3028.
10. YANG Shiming. Numerical heat transfer [M]. 4th ed. Beijing, China: Higher Education Press, 2006: 41-46.

11. CHEN F, ZHAO Y, MA X. An efficient calculation for the temperature of dry air-core reactor based on coupled multi-physics model [C]// Electromagnetic Field Problems and Applications (ICEF). Dalian, China: IEEE, 2012: 1-4.
12. YE Zhangang. Temperature rise test of dry-type air-core reactor and calculation of its winding temperature rise [J]. Transformer, 1999, 36 (9): 6-12.
13. AN Liqiang, WANG Zhangqi, TANG Guiji. 3D-temperature field prediction by FEM and temperature rise test for dry-type reactor [J]. Journal of North China Electric Power University, 2002, 29 (3): 75-78.
14. LIU Zhigang, GENG Yingsan, WANG Jianhua, et al. Design and analysis of new type air-core reactor based on coupled fluid thermal field calculation [J]. Transactions of China Electrotechnical Society, 2003, 18 (6): 59-63.
15. ZHANG Yujiao, QIN Weinan, LIU Wenjun, et al. Ventilation structure improvement of reactor based on coupled field numerical analysis [J]. High Voltage Apparatus, 2014, 50 (8): 62-65.