

Design of Three-Section Current Protection Experimental Device for Single

Bao Xiaodong¹, Wang Yongzhi^{1,*}, and Jin Liang¹

¹College of Instrumentation & Electrical Engineering, Jilin University, Changchun, China

Abstract. Based on the design idea of microcomputer protection, a set of three-section current protection experimental device was designed by using MCU. Using MCU as the core control of experimental device, the circuits were designed, including the passive filter, current acquisition and signal output; real-time current data were collected. When the current exceeded the setting value, the three-section protection had the single hop or linkage, thereby sending out a tripping signal to the simulated circuit breaker. By testing, the device could store data such as real-time acquisition of the current, alarm, tripping and closing in local database and cloud database, and realize remote monitoring and analysis of devices through cloud service. The device basically reached the goal of laboratory experiment teaching.

1 Introduction

Relay protection is an important part of ensuring the safe and stable operation of power system. The microcomputer relay protection plays a great role in the operation and maintenance of smart grid in the new era. The three-section current protection, as a classical power line protection method, consists of instantaneous current quick break protection (section I), the time delay instantaneous overcurrent protection (section II) and definite time overcurrent protection (section III), which can coordinate each other and complete the current protection of the line [1].

This paper adopted principle and design method of the microcomputer protection, designed and implemented control circuit such as AC current acquisition. Taking Raspberry Pi as the control core, the current protection device realized not only the real-time acquisition, monitoring, display and local storage of current, but also the cloud storage and remote monitoring of the related current data.

2 Hardware design

The hardware design of the device included Raspberry Pi interface, the current acquisition circuit, the low pass filter circuit, the signal output circuit and so on. Figure 1 showed the hardware block diagram of the device. The primary side current was simulated by the PMU-B backup power self-input device tester which collected the corresponding secondary current

through the transformer, then the PSS02 simulated circuit breaker received the tripping signal and implemented the tripping operation.

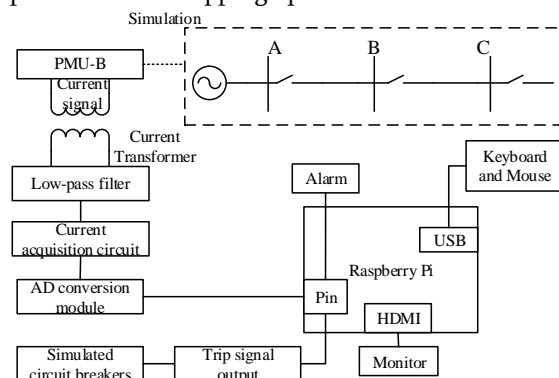

Fig.1. Diagram of hardware components

2.1 Raspberry Pi

Using the embedded Linux operating system, Raspberry Pi, a credit-card sized card type computer, provides interfaces of the normal computer USB, HDMI and audio, whose 40 pins provide Raspberry Pi custom module development and programming control, thereby having stronger performance than that of single-chip microcontroller, and providing computer programming experience [2].

2.2 Low pass filter circuit

When the power system failed, the instantaneous voltage and transient current of the initial state of the fault would produce high frequency components

* Corresponding author: iamwangyongzhi@126.com

which are far greater than the power frequency. The frequency could even reach more than 2000Hz. According to the Nyquist sampling theorem $f_s > 2f_m$, the sampling frequency must be above 4000Hz. Because the protection device mainly reflected the power frequency signal of 50Hz, before signal sampling, a RC passive low pass filter circuit [3] was used to filter out the frequency components higher than $f_s/2$, so as to reduce the sampling frequency (as shown in Figure 2).

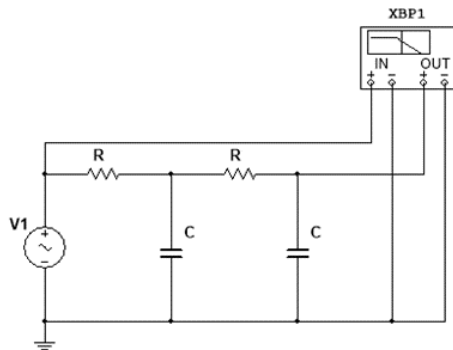

Fig.2. Second-order passive filter circuit

According to the system frequency response function of the second order RC passive low pass filter:

$$|H(j\omega)| = \frac{1}{\sqrt{(1 - \omega^2 R^2 C^2)^2 + 9\omega^2 R^2 C^2}} \quad (1)$$

The calculated cut-off angular frequency was shown as follows:

$$\omega_c = \frac{1}{2.6724RC} = \frac{0.3742}{\tau} \quad (2)$$

The cut-off frequency was shown as follows:

$$f_c = \frac{\omega_c}{2\pi} = \frac{0.06}{\tau}, \quad \tau = 1.5 \times 10^{-5} \quad (3)$$

The filter capacitance of a low pass filter with cut-off frequency of 4kHz was selected between 0.01 and 0.001 μ F. According to the nominal value of the capacitance, the capacitance was selected 0.0047 μ F and the resistance was 3191 Ω ; and the metal film resistor with 1% precision and 3.32k Ω resistance was selected as electric resistance.

2.3 Current acquisition circuit

The current acquisition circuit got secondary side smaller current that reflected primary side larger current through the current transformer [4,5]. The current was filtered through the passive low-pass filter, and then regulated value of feedback resistance R through the conditioning circuit and operational amplifier to obtain the corresponding output voltage (as shown in Fig. 3). After the A/D conversion of the output voltage, the voltage value U was collected.

According to formula $I = U/R \cdot n$ (R was feedback resistance value, n was the ratio of primary winding and secondary winding of current transformer), the secondary side current value that reflected the primary side current value could be calculated.

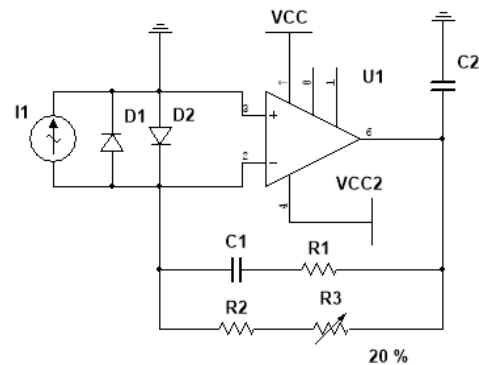

Fig.3. Circuit diagram of current acquisition

In the circuit, the operational amplifier was the OP07 series. The experience value of compensation capacitance C1 was from 0.01 to 0.033 μ F, and the compensation resistance was:

$$R1 = 95 \times \frac{22R2 / \Phi C2 - 1}{2} \quad (4)$$

Among them, the R2 was the feedback resistance, the unit was k Ω , and $\Phi C1$ was uncompensated phase shift value marked on mutual inductor, and the unit was fen.

2.4 A/D analog-to-digital conversion

High-Precision AD/DA Board expansion board made by Microsnow Electronics Company was directly used for A/D analog-to-digital conversion. A/D input the voltage output that connected with the current acquisition circuit. and A/D output was directly connected to the external pins of Raspberry Pi, so as to achieve analog-to-digital conversion of input analog current value, thereby getting the corresponding current value.

2.5 Signal output circuit

The signal output circuit was mainly used for analog trip signal output and fault alarm while three-section current protection was operated. The buzzer and LED signal lamp were directly connected to the Raspberry Pi pin after current limitation, as shown in Figure 4. When the current protection was operated, the corresponding LED signal lighted up. At the same time, the buzzer started and sent out the tripping signal.

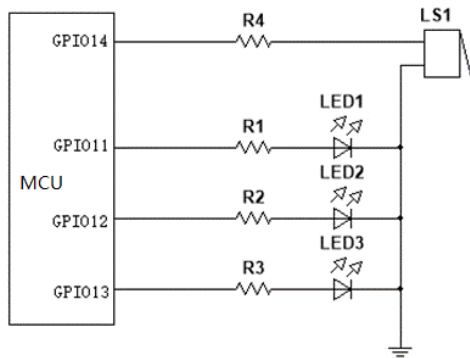

Fig.4. Circuit diagram of signal output

3 Software design

3.1 System function

The functions of the software include current acquisition, current monitoring and data storage, and analysis display (as shown in Figure 5). The current acquisition mainly drove the hardware with the software to implement analog-digital conversion thereby obtaining a current value; current monitoring could realize real-time display and threshold detection to the current data, while issuing the corresponding alarm signal and switch signal [6]; the data storage included local storage and cloud storage; the interface included adjustment setting and data query display.

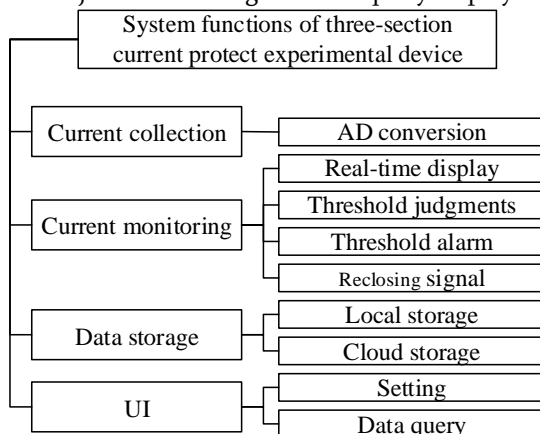

Fig.5. Diagram of system function

3.2 Application scene

Figure 6 showed interactive application scenarios such as a device of local acquisition, storage and cloud transmission, remote monitoring and so on. After collecting the current data, the device first saved it to the local MySQL database, and at the same time invoked the written data service in the cloud through the network and saved the data to the cloud database (renting Ali cloud server). The local area network

monitoring computer could directly access the local database of Raspberry Pi and implemented real-time monitoring. The remote computer could send requests to the cloud through the network. By invoking the written web data servicer, the application server returned the eligible monitoring data, such as real-time current value and setting value, so as to realize asynchronous remote monitoring and analysis.

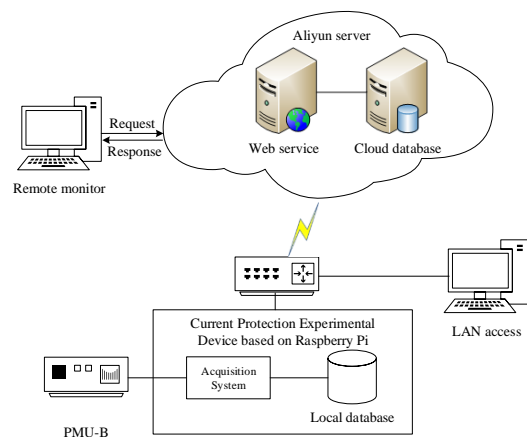

Fig.6. Interactive work pattern of LAN and cloud server

3.3 Main program design

Figure 7 showed the main program flow of Raspberry Pi. After the program started, the system initialization was first launched, and then A/D conversion, current value acquisition, data analysis, data storage, display and real-time monitoring, real-time comparison of current and threshold; when the threshold was exceeded, a corresponding signal and tripping alarm signal were sent out, and the above-mentioned motion data was stored.

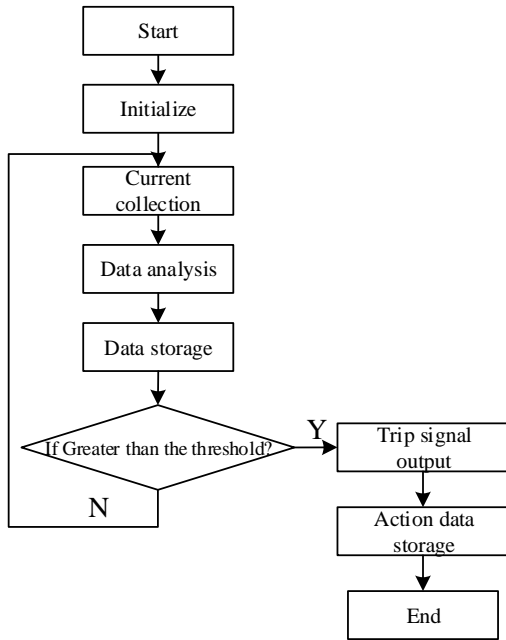

Fig.7. Flow chart of main program

3.4 The setting of adjusting value and current monitoring

The current monitoring completed the dynamic display of the current acquisition and the current setting value judgement of the three-section protection [7,8]. The setting interface could be used to determine the current setting value through the LAN, as shown in Figure 8.

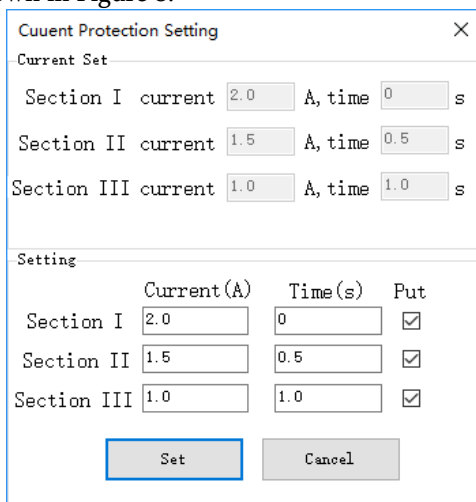

Fig.8. UI of setting form

When the current exceeded protection current setting value of section I, the program directly sent out tripping signal. If the action failure of section I occurred, section II and section III protection would be started; when the current exceeded protection current setting value of section II, the program delayed by setting. After the delay, the tripping signal was sent out. If the action failure of section II occurred,

section III protection would be started; when the current exceeded protection current setting value of section III, the program delayed by setting. After the delay, the tripping signal was sent out. If the action failure of section III occurred, a device fault alarm would be sent out. The program design process was shown in figure 9.

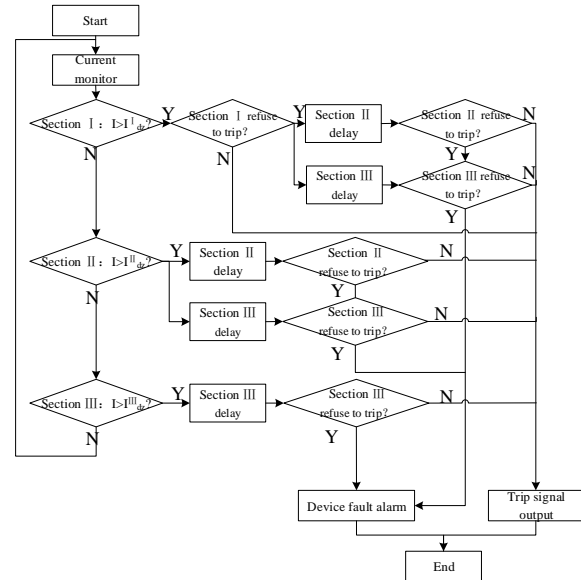

Fig.9. Flow chart of current monitoring program of three-stage current protection

3.5 Data storage

While the current data was monitored, the collected current values were directly stored in the local MySQL database [9] in Raspberry Pi Linux operating system. When the current exceeded the threshold, the current protection operation was carried out. The program saved the current value, current protection and failure report to the database, which facilitated the later data processing and analysis.

Raspberry Pi could store data to local and cloud database [10] through the access of network port or Wi-Fi to LAN or Internet, and form a distributed monitoring [11] based on cloud computing for current protection.

4 Experimental results

The power output of PMU-B backup power self-input device tester produced by Beijing PONOVO was used as the current input of the device. The trip signal output of the device was used as the signal input of PSS02 simulated circuit breaker. Because the maximum allowable current of PSS02 simulated circuit breaker was 2.5A, the setting value of the three-section current protection device was

respectively set as: section I: current 2A, action time 0s; section II: current 1.5A, action time 0.5s; section III: current 1A, action time 1s. By setting the PMU-B detector, the normal running current was 0.5A, so that the current would increase instantly during the operation thereby achieving the setting value, and testing the current protection action of different sections.

After setting up the PMU-B detector, 20 tests were carried out on the three-section current protection operation, and the experimental results were shown as Table 1.

Table1. Experimental test results

Test	Experimental number	Correct number	Rejected number
Section I	20	20	0
Section II	20	20	0
Section III	20	20	0

Fig. 10 showed a graphical interface for real-time operation of the current under normal running state. Fig. 11 showed a real-time monitoring and changing effect of section I protection operation. Figure 12 showed a real-time monitoring chart for section II protection operation.

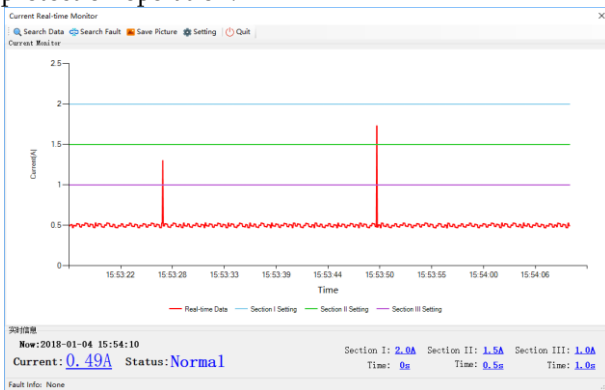

Fig.10. Line chart of current real-time monitoring



Fig.11. Monitoring chart of first protection action



Fig.12. Monitoring chart of second protection action

5 Conclusion

By using the existing tester, simulated circuit breaker and other laboratory experimental devices in power system relay protection laboratory, the three-section current protection device could not only realize the real-time monitoring of the current based on Raspberry Pi, but also make the current corresponding protective action. The accurate test results met the expected design requirements, which could be preliminarily used in the research of teaching of experimental relay protection.

The next thing to do is that the interactive operation of the local device with the cloud will be carried out, such as the operation of adjusting the setting value through the cloud.

Acknowledgments

This research has been jointly supported by National Key R & D Program of China (2016YFC0600501), National Natural Science Foundation of China (2016YFC0600501-4) and the State Key Program of National Natural Science of China (41430320).

References

1. YANG Fan. Xi'an: Xidian University, (2015)
2. WANG Jiewang, WANG Ruibao. Electronic Design Engineering. **24**, 169-171 (2016)
3. GAO Lijie. Journal of Changjiang Engineering Vocational College. **23**, 42-44 (2006)
4. QIU Shihui. Science Technology and Engineering. **12**, 7402-7407 (2012)
5. WANG Yongzhi, Zhang Yuli, Zhang Fuliang, et al. Mathematical Problems In Engineering. 1-10 (2013)
6. PAN Mingming, LIN Chenxiang, WANG Xuan, et al. Technology and Engineering. **16**, 107-111 (2016)
7. ZHENG Shuang, XIONG Jinfei, JIANG Qiwen, et al. Telecom Power Technology. **33**, 96-99 (2016)

8. YANG Yujie, ZHU Liancheng, LI Fuyun, et al. Journal of University of Science and Technology Liaoning. **39**, 141-145 (2016)
9. ZHENG Lan. Database and Information Management, **6**, 59-61 (2010)
10. HE Wenna. Changchun: Jilin University, (2013)
11. YANG Hongshan, Zhang Minrong, Sun Ping. Computer Applications and Software. **32**, 51-55 (2015)
12. Wang Yongzhi, Zhang Yuli, Yi Jining, et al. Mathematical Problems In Engineering. 1-11 (2014)