

Design of a Low-Cost Fixed Wing UAV

Mochammad Ariyanto*, Joga D. Setiawan, Teguh Prabowo, Ismoyo Haryanto, Munadi

Department of Mechanical Engineering, Diponegoro University, Semarang, Indonesia

Abstract. This research will try to design a low cost of fixed-wing unmanned aerial vehicle (UAV) using low-cost material that able to fly autonomously. Six parameters of UAV's structure will be optimized based on basic airframe configuration, wing configuration, straight wing, tail configuration, fuselage material, and propeller location. The resulted and manufactured prototype of fixed-wing UAV will be tested in autonomous flight tests. Based on the flight test, the developed UAV can successfully fly autonomously following the trajectory command. The result shows that low-cost material can be used as a body part of fixed-wing UAV.

1 Introduction

Recently utilization of Unmanned aerial vehicle (UAV) has grown significantly especially for fixed wing and rotary wing type. The UAV is controlled by the pilot (operator) in the ground control station. UAV can fly autonomously based on programmed flight plans into the flight controller board. Many users/hobbyist build fixed-wing Unmanned Aerial Vehicle (UAV) by themselves, they have to design, calculate aerodynamic performance, and manufacture the UAV by themselves. Furthermore, they have to decide which mechanical and electrical components needed in order to build the UAV that can perform as intended. Building UAV is cheaper than buying factory-built UAV. Design and manufacture of UAV require design process, manufacturing, and numerous flight tests until the UAV has good tracking performance both in manual and autonomous flight.

This research will focus on the design optimization of six parameters to achieve low cost and easy to manufacture fixed-wing UAV. The parameters are basic airframe configuration, wing configuration, straight wing, tail configuration, fuselage material, and propeller location. The selection of structural configuration and material of the UAV is presented in section 2. The fixed-wing UAV is equipped with available commercial flight controller board. After the prototype is built, it will be tested to fly autonomously following the predefined trajectory.

2 UAV Fixed Wing Design

In this section, six design configuration structures will be considered i.e., basic airframe configuration, wing configuration, straight wing, tail configuration, fuselage material, and propeller location. Three basic airframe configurations are considered. There are four

* Corresponding author: mochammad_ariyanto@ft.undip.ac.id

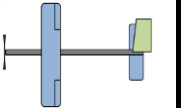
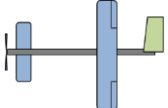
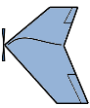

things to consider, namely the ease of manufacturing process, stability, ease of hand launch, and mass. Table 1 shows the comparison between the three basic airframe configurations, where configuration five is the best, and configuration one is the worst. In the conventional configuration, horizontal tail is at the back of the fuselage. Horizontal tail and vertical tail can be attached to each other. The back of the fuselage can be simplified in the form of an aluminum rod to reduce the weight of the system. Because of the aluminum rod, horizontal tail and vertical tail can be fitted strongly enough without the need for a special cradle, just by using a clamp. □

Table 1. Comparison of basic airframe configuration.

Design Parameters	Weight	Conventional	Canard	Flying Wing
				
Ease of manufacturing process	0,3	4	3	5
Stability	0,3	5	4	2
Ease of hand launch	0,2	5	5	4
Mass	0,2	4	4	5
Total Σ (weight x value)	1	4,5	3,9	3,9

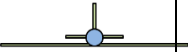

Three vertical wing positions against the fuselage will be considered. There are four things to consider, namely the ease of manufacturing process, stability, ease of hand launch, and ground clearance. Table 2 shows the comparison of the three vertical positions of the wings to the fuselage. In this research, the selected configuration is high wing configuration.

Table 2. Comparison of wing configuration.

Design Parameters	Weight	High Wing	Mid Wing	Low Wing
				
Ease of manufacturing process	0,3	5	3	4
Stability	0,3	5	4	3
Ease of hand launch	0,2	5	4	3
Ground Clearance	0,2	5	4	3
Total Σ (weight x value)	1	5	3,7	3,3

Planform is a wing shape when the wing is viewed from above. This study does not require a UAV that prioritizes speed. The wing planform suitable for low-subsonic planes is straight wing [1]. Three planform of straight wing are considered. There are three things to consider, namely the ease of manufacturing process, structural strength, and aerodynamic performance. Table 3 shows the comparison between the three planform of straight wing. In terms of aerodynamics and structure, rectangular wing tends to be inferior to two other wing planform. However, in terms of manufacturing, this wing is the easiest and cheapest to make because it has only one size air foil [1].

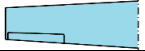
Table 3. Comparison of straight wing.

Design Parameters	Weight	Rectangular	Tapered	Prismatic Mid-Section
				
Ease of manufacturing process	0,6	5	3	4
Strength of structure	0,2	4	5	5
Aerodynamic performance	0,2	3	5	4
Total Σ (weight x value)	1	4,4	3,8	4,2

Three tail configurations are considered. The tails are conventional, T-Tail, and V-Tail. There are three things to consider, namely the ease of manufacturing process, weight structure, and aerodynamic performance. Table 4 shows the comparison between the three tails. Conventional tail configurations are the most common configuration used in UAVs. This configuration is easy to build because it has a simple, lightweight, and powerful structure. In this setting, the selected tail configuration is a conventional configuration.

Table 4. Comparison of tail configuration

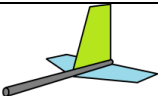
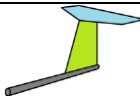
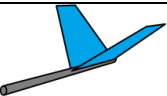
Design Parameters	Weight	conventional	T-Tail	V-Tail
				
Ease of manufacturing process	0,4	5	4	4
Weight of structure	0,4	5	3	5
Aerodynamic performance	0,2	4	5	3
Total Σ (weight x value)	1	4,8	3,8	4,2

Three types of fuselage materials are presented in this study. There are five things to consider, namely the ease of manufacturing process, structural strength, price, availability, and weight of the structure. Table 5 shows the comparison between the five types of fuselage materials. Based on Table 5, the selected fuselage material is plastic tube and aluminum cylinder.

Table 5. Comparison of fuselage material.

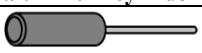
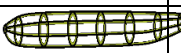
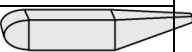
Design Parameters	Weight	Plastic tube and aluminum cylinder	Wood Balsa	Foam
				
Ease of manufacturing process	0,2	5	3	4
Strength of structure	0,2	5	2	3
Price	0,2	5	2	5
Availability	0,2	5	3	5
Weight of structure	0,2	4	5	4
Total Σ (weight x value)	1	4,8	3	4,2

Four propeller locations are considered in the selection of propeller locations. Table 6 shows the comparison between the four propeller locations. The pusher configuration has a motor located behind the fuselage. Similar to the tractor configuration, the position of the propeller axis is parallel to the fuselage symmetry axis (longitudinally) so that the distance from the edge of the propeller to the ground (ground clearance) becomes minimal. This increases the risk of propeller breaks during landing. Since the propeller is at the back of the UAV, the risk of throwing hands is exposed to the edge of the propeller when the hand launch is enormous. In addition, since the UAV in this study will use aluminum cylinder as the rear fuselage, the installation of the motor on the aluminum cylinder requires a special cradle, thus increasing the difficulty of manufacturing the UAV.

Table 6. Comparison of propeller location.

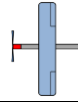
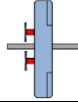
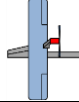
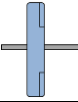
Design Parameters	Weight	Tractor	Twin Engine	Mid Engine	Pusher
					
Ease of manufacturing process	0,3	5	3	3	4
Safety when hand launch	0,3	5	5	5	3
Mass	0,2	5	3	4	5
ground clearance	0,2	3	4	5	3
Total Σ (weight x value)	1	4,6	3,8	4,2	3,7

In the fuselage design, the selected fuselage material is a plastic drawing tube and an aluminum cylinder. The plastic drawing tube is for the front fuselage and aluminum cylinder for the rear fuselage. The plastic drawing tube used in this study has a diameter of 8 cm. The aluminum cylinder has a diameter of 1.2 cm. Figure 1 shows the fuselage design. From its original size, the plastic drawing tube is modified so that its length becomes 62 cm. Aluminum cylinder has a length of 59 cm but put 10 cm into the drawing tube. The final 3D design is presented in Figure 2.

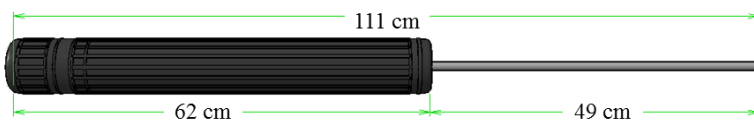

Fig. 1. Design of fuselage □

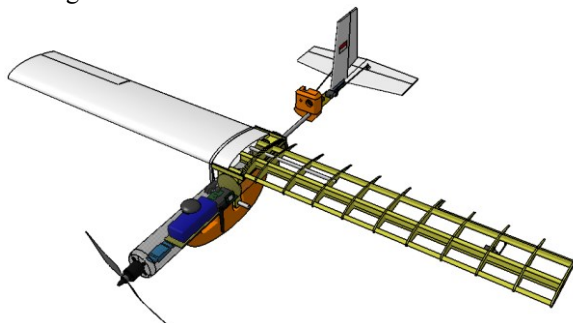

Fig. 2. Isometric view of the final design of fixed-wing UAV □

3 Prototype

After the design process is complete, next step process is to manufacture the fixed-wing UAV. The prototype produced in this study can be seen in Figure 3. The camera is mounted on an aluminum cylinder using a stand made of EVA (ethylene-vinyl acetate) foam. The stand is also useful for damping vibrations from the UAV structure to the camera for better video recording quality. The motor used in this research is brushless DC motor. The brushless DC motor has better efficiency and power to weight ratio than the brushed DC motor. In this study, the brushless DC motor used is SunnySky X2820-800KV. Based on the data specifications SunnySky X2820-800KV, the motor can produce a maximum thrust of 2.24 kg when paired with a 12 x 6 propeller and 14.8 V battery. So that, the propeller used is propeller 12 x 6 made of nylon. Propeller made from nylon is cheaper than wood or carbon fiber. To obtain a thrust of 2.24 kg, the specifications of the SunnySky X2820-800KV motor require the use of 14.8 V batteries. The batteries used in this study are the most commonly used batteries on RC plane, the lithium polymer batteries. Four servos are used to drive the ailerons elevator, and rudder.

4 Flight Test

In this research, improving tracking performance in UAV is conducted gradually. Before improving tracking performance, fixed-wing UAV performance in the entering waypoints is improved first. In the first Flight test, the UAV is unable to enter the waypoint accurately. On the second flight test, K_p , K_i , and K_d on roll and pitch controller still use default settings, same as the first flight. However, to improve the performance of the UAV in entering the waypoint, the Turn Control Period and Waypoint Radius parameters must be tuned on the second flight.

PID is the widely used compensator for controlling the stability of quadrotor [2], and also PID is commonly employed in fixed-wing UAV [3]. In this research, PID control is utilized to control roll and pitch angles of fixed-wing UAV. In the first flight test, the Turn Control Period parameter value is 20. The UAV must turn sharper in order to enter waypoints with better accuracy. Therefore, the value of the Turn Control Period parameter must be decreased. In the second flight test, the value of the Turn Control Period parameter is decreased by 25% so that the value becomes 15. In the first flight test, the value of Waypoint Radius parameter is 30 m. In the second flight test, the value of the Waypoint Radius parameter is reduced to 20 m. This is done so that when entering the waypoint, UAV is not too far from the center of Waypoint Radius and can turn sharper. Table 7 shows the setting values on the roll, pitch, and navigation controller.

Table 7. Control parameters for first and second flight test.

Controller	PID parameters	Values	
		First flight test	Second flight test
Roll	$[K_p K_i K_d]$	[0.415 0.05 0.02]	[0.415 0.05 0.02]
Pitch	$[K_p K_i K_d]$	[0.405 0.04 0.02]	[0.405 0.04 0.02]
Navigation	Turn Control Period	20	15
Navigation	Waypoint Radius (m)	30	20

In the second flight test, the UAV is capable of autonomous flight and video recording as shown in Figure 3. Figure 4 shows a two-dimensional view of the UAV flight path in Auto mode on the second flight test. On the second flight test, it appears that the UAV can enter the waypoint accurately. However, it appears that the flight path does not coincide with the track. That is, the tracking performance is still not accurate enough. □



Fig. 3. Fixed-wing UAV in autonomous flight, (a) Flight above 100 m from terrain, (b) First person view display □

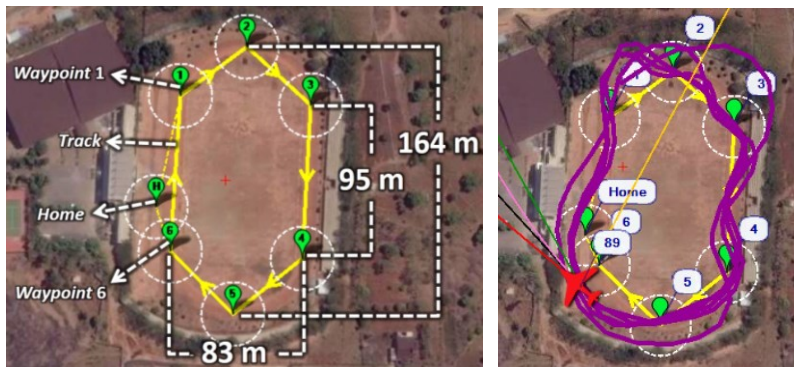

Fig. 4. UAV fixed wing trajectory, (a) Trajectory command, (b) Trajectory response

5 Conclusion □

In this research, a low-cost fixed-wing UAV has been successfully designed and built. The material that was used for creating a fixed-wing UAV should be lighter, stronger, cheaper, and easier to manufacture. For future flight test, the control parameters will be tuned to get the better result. The final selected structure configurations for low cost fixed-wing UAV are conventional airframe, high wing, rectangular wing, conventional tail configuration, tractor propeller, plastic tube and aluminum cylinder for fuselage material. Based on the flight test, the developed UAV can successfully fly autonomously following trajectory command. The result shows that low-cost material can be used as a body part of fixed-wing UAV. □

References

1. E. Torenbeek. *Synthesis of Subsonic Airplane Design*. Springer Netherlands, (1982)
2. J. D. Setiawan, Y. D. Setiawan, M. Ariyanto, A. Mukhtar and A. Budiyo, *Development of real-time flight simulator for quadrotor*, 2012 International Conference on Advanced Computer Science and Information Systems (ICACSIS), Depok, 59-64, (2012)
3. F. A. Warsi et al., *Yaw, Pitch and Roll controller design for fixed-wing UAV under uncertainty and perturbed condition*, 2014 IEEE 10th International Colloquium on Signal Processing and its Applications, Kuala Lumpur, 151-156, (2014)