

Design of High Efficient MPPT Solar Inverter

K. A. Sunitha , G Prem Kumar, Nidhi Priya and Jatin Verma

Department of Electronics and Instrumentation, SRM University, India

Abstract. This work aims to design a High Efficient Maximum Power Point Tracking (MPPT) Solar Inverter. A boost converter is designed in the system to boost the power from the photovoltaic panel. By this experimental setup a room consisting of 500 Watts load (eight fluorescent tubes) is completely controlled. It is aimed to decrease the maintenance cost. A microcontroller is introduced for tracking the P&O (Perturb and Observe) algorithm used for tracking the maximum power point. The duty cycle for the operation of the boost convertor is optimally adjusted by using MPPT controller. There is a MPPT charge controller to charge the battery as well as fed to inverter which runs the load. Both the P&O scheme with the fixed variation for the reference current and the intelligent MPPT algorithm were able to identify the global Maximum power point, however the performance of the MPPT algorithm was better.

1 Introduction

Energy plays vital role for development in all sectors. With depletion of fossil fuels used for power generation and increase in demand for power, the gap between supply and demand is becoming more. Renewable energy sources can only provide solution to it. Sun radiates 180 billion MW of energy over Earth. Just one hour of this energy could meet power needs of entire planet for a year. India receives 5000 Trillion KWh of energy from Sun per annum. This energy is clean, pollution free and inexhaustible.

Photovoltaic (PV) is a method of generating electrical power by converting solar radiation into direct current electricity using semiconductors that exhibits the photovoltaic effect.

PV panel is connected to the charging circuit. In a photovoltaic system the maximum power output changes with load, temperature and the solar intensity.

In this paper we have designed an efficient MPPT solar inverter. Purpose of investment in solar power project is to enter in development of green energy technology, which is the only ultimate source of energy for future generations. This system is easy to fit and install in the existing systems [1]. The higher performance of the proposed intelligent system has been verified in [2]. The solar tracking itself can be continuous or step tracking, depending on the application. Continuous tracking is needed for highly accurate systems [3]. The controller aims at maximizing the solar PV cell's efficiency by forcing sunlight to be incident perpendicularly [4].

The solar power system is also used in the solar powered vehicles [8]; it can also be used in residential applications [9].

2 The proposed PV system

Photovoltaic (PV) is a method of generating electrical power by converting solar radiation into direct current electricity using semiconductors that exhibits the photovoltaic effect. The intensity of sun's light is the reason for generation of electricity and not the heat. For example, compared to the month of January, April will provide less power as heat is more, that may affect the working of device.

An Arduino is programmed in such a way to rotate the stepper motor to the desired angles. The motor drives the panel to the maximum power output positions. The generated voltage goes to the voltage regulator, passing through the control unit it goes to the inverter. From the inverter we get the AC output power.

A 22 Volt, 120 Watts solar panel gives around 7.59 ampere current in bright light. The solar panel with the inverter can produce a maximum power continuously. The batteries used are connected in parallel. The battery will store the energy produced by the panel. This battery is connected to the Inverter. Battery used in our system is standard 12 V battery. Inverter is used to convert the input DC voltage from the battery into output AC voltage.

The MPPT algorithm acts as the interface between the PV array and the energy storing device. For maximum power point tracking (MPPT) perturb and observe method (P&O) is used.

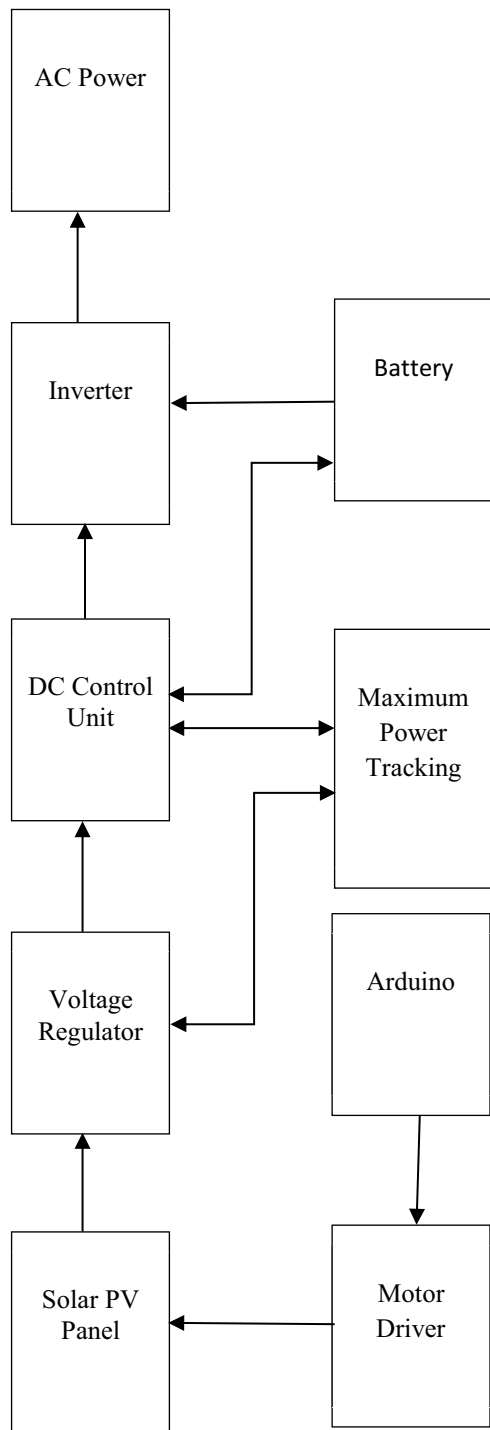

Figure 1. Block diagram of the solar inverter.

3 Flow chart

The flow chart shows the sequential movement of the whole process. The program checks the time and decides the position of the panel. Four time domains are taken into consideration i.e. 10 am, 12 noon, 2pm (14 hours in the 24-hour clock) and 17 hours or 5 pm. Position 1 is maintained till 10am, after 10 the position changes to 2 till 12 noon. After that the panel takes position 3 till 5pm. After this the panel comes back to position 1 and remains at that position till 10am. And the process continues the same way.

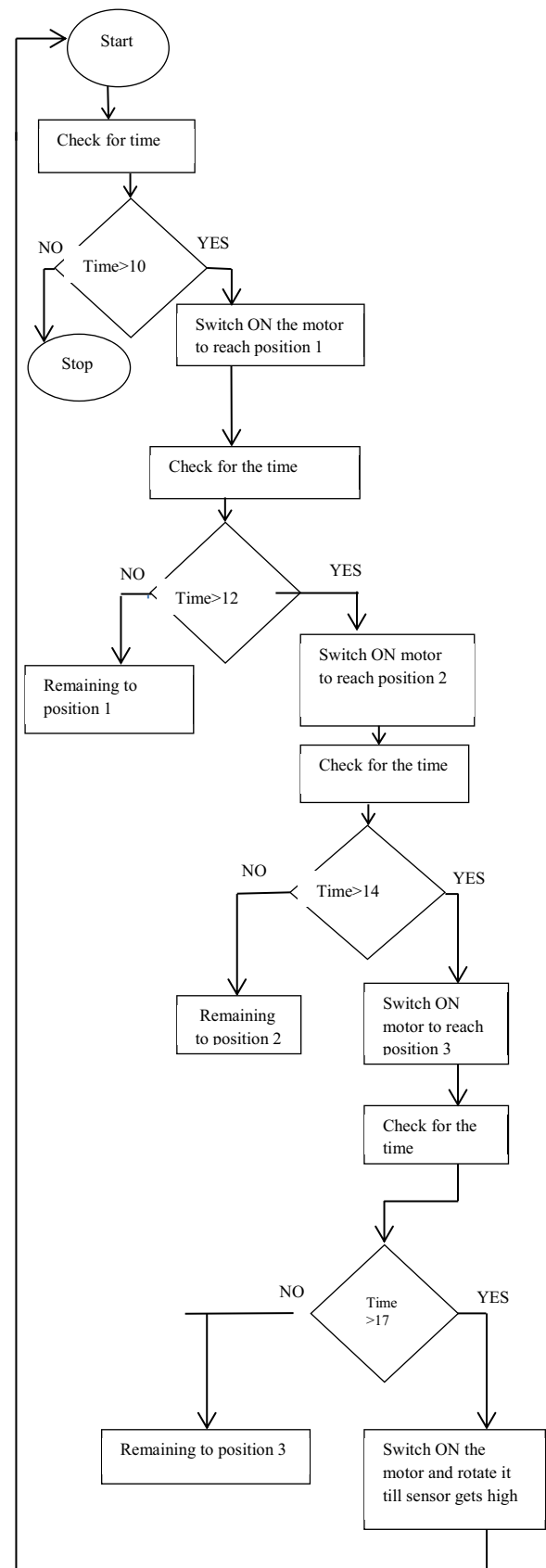

Figure 2. Persistent loop of the solar inverter.

4 Theory and modeling

When the light falls on the solar panel, it produces a dc current. As the light falling on the panel is not constant the dc voltage produced by the panel is also not a constant value. This goes to the voltage regulator which regulates and stabilizes the dc output. The regulated voltage then goes to the dc control unit. The controller consists of a chopper circuit. Depending on its duty cycle, it transfers the input power to the output power. It is also called the buck boost converter. The output then goes to the inverter circuit. In the inverter circuit the dc output is converted to AC output. This AC power can directly be used.

Apparently, the dc output thus generated can be stored in the battery. The inverter circuit was made using transformer, capacitor, dc Battery etc.

4.1 PV panels

Photovoltaic (PV) is a method of generating electrical power by converting solar radiation into direct current electricity using semiconductors that exhibits the

photovoltaic effect. Photovoltaic power generation employs solar panels comprised of an array of cells containing a photovoltaic material. The PV generator is formed by the combination of many PV cells connected in series and parallel to provide the desired value of the output voltage and current. PV Panel is connected to the charging circuit.

PV Panel Specifications: -

- 1) General specifications:
 - Manufacturer: AMMVEE
 - Model: D2160Wp
 - Solar cell: Multi crystalline.
 - Solar cell shape: Rectangle
- 2) Electrical specifications:
 - Open circuit voltage: $V_{oc} = 22.0$ volt.
 - Short circuit current: $I_{sc} = 6.0$ ampere.
 - Maximum voltage: $V_{mp} = 36.7$ volt.
 - Maximum current: $I_{mp} = 7.59$ ampere.
 - Maximum power at STC: $P_{max} = 120$ Wp.
 - Operating Temperature/Humidity = $47\text{ }^{\circ}\text{C} + 2$.

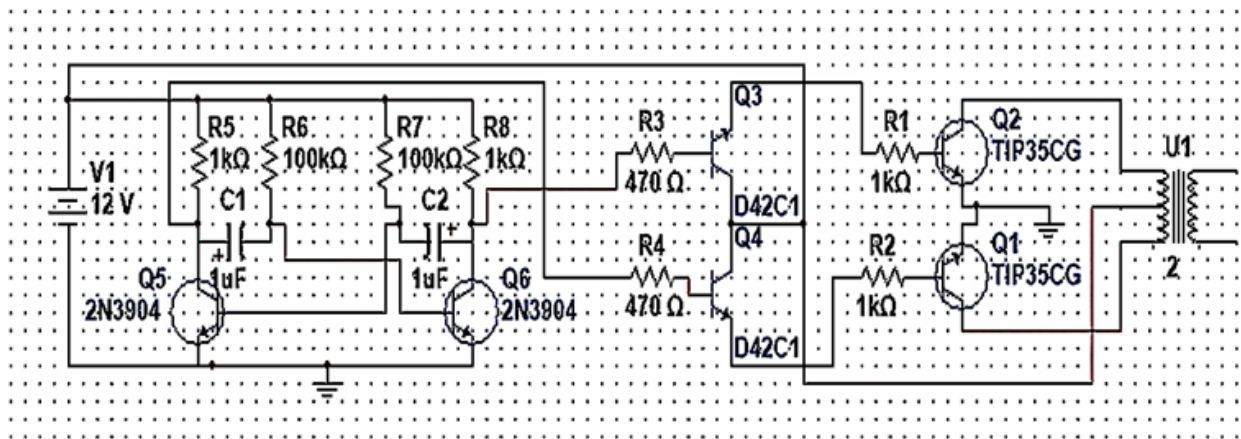

Figure 3. Inverter circuit.

4.2 Inverter

It is used to convert the DC input voltage from battery or PV panel into AC voltage. Inverter used here does not produce a pure sinusoidal output rather it generates square pulses which is connected to almost all the appliances now-a-days except some high frequency appliances. Power transistors are used to drive the transformer.

After adding protection circuits/components for over voltage protection, over current protection, over load protection this project will be a complete solution to the energy crisis problem.

There is only one variable resistance in this circuit diagram which is used to adjust frequency of 240V AC output voltage. The frequency meter is adjusted to frequency of 50HZ to 60HZ as per the requirement.

4.3 Battery

Here, Battery means the series of batteries that are connected in parallel. The battery will store the energy produced by Panel. This block shown above (Fig.01.) is connected to the Inverter. Battery used in our system is standard 12 V of 45 Ah.

Table 1. Power values at different time and positions.

VOLTAGE MEASURED VARYING THE LOAD (V)	10AM				3PM				12 Noon	
	STATIONARY		TRACKING		STATIONARY		TRACKING			
	I(Amp)	P(W)	I(Amp)	P(W)	I(Amp)	P(W)	I(Amp)	P(W)	I(Amp)	P(W)
20	00	00	00	00	00	00	00	00	00	00
18	1.43	25.74	1.48	26.64	1.44	25.92	1.52	27.36	2.20	39.6
16	2.96	47.36	3.26	52.16	2.47	39.52	3.1	57.6	3.67	58.72
14	4.50	63	4.51	63.14	2.89	40.46	4.7	65.8	4.79	67.07

12	5.44	65.28	5.75	69	3.15	37.8	5.42	65.04	5.05	60.6
10	5.82	58.2	6.42	64.2	3.43	38.9	5.85	58.5	5.38	53.8
08	6.01	48.08	6.78	54.24	3.89	31.12	6.30	50.4	6.06	48.48
06	6.14	36.84	6.80	40.74	4.22	25.32	6.56	39.36	6.46	38.46
04	6.20	24.8	6.85	27.2	4.74	18.96	6.78	27.12	6.89	27.56
02	6.27	12.54	6.87	13.7	4.66	8.64	6.79	12.81	7.15	14.3
00	6.31	00	6.91	00	4.55	00	6.72	00	7.59	00

*Maximum power has been tracked and bolded

5 Simulation results and analysis

The experiment was performed by keeping the panel at 3 different angles. Each time it was made facing the sun in a way that most of the sun rays fall perpendicularly on it. The 1st angle is 45 degrees facing east, the 2nd one is 180 degrees and the 3rd angle is 45 degrees facing the west. The voltage and current are measured in both stationary and tracking positions. By the data's received we plot a graph and obtain the maximum point tracking graph. By these graphs we see that the tracking system produces a higher output power than the stationary set up. In the table below 'I' denotes current value in amperes and 'P' denotes the output power produced in watts.

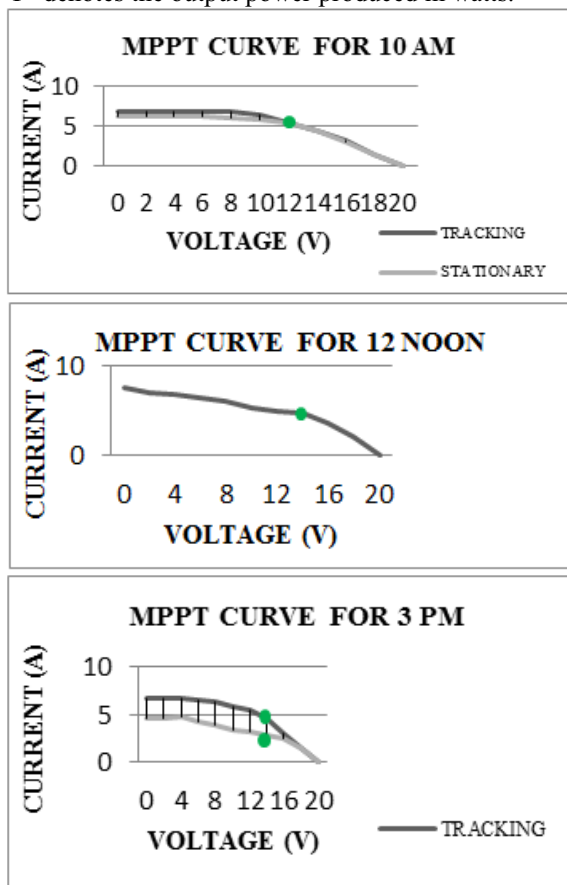

*Maximum power marked in each case
Figure 4. Graphs showing the V-I curve.

6 Conclusions

In this paper, we presented that a tracking system is more efficient than the existing stationary one. The output power is more in all the time domains in which the experiment was carried out. In the developed MPPT solar inverters the power consumed by the tracking system is found to be more, which can be reduced in the future works.

7 Future scope

The future work consists of making a solar tracking system based on Fuzzy Logic which could help it to improve the efficiency and output power generated.

References

1. M. G. Simoes and N. N. Franceschetti, IEE Proc.-Electr. Power Appl., **146**, no. 5, (September 1999)
2. N. S. D'Souza, L. A. Lopes and X. Liu, Concordia University Department of Electrical and Computer Engineering, IEEE, (2005)
3. M. Alata, M..A. Al-Nimr, Y. Qaroush, Energy Conversion and Management, **46** (2005) 1229–1245
4. W. Batayneh, A. Owais, M. Nairoukh, Elsevier, Automation in Construction **29** (2013) 100–106
5. C. S. Chiu, IEEE transactions on Energy conservation, **25**, No. 4, (December 2010)
6. J. S. Choi, D. Y. Kim, K. T. Park, C. H. Choi and D. H. Chung, International Conference on Smart Manufacturing Application (April. 9-11,2008) in KINTEX, Gyeonggi-do, Korea
7. M. Taherbaneh, H. Ghaforifard, A. H. Rezaie and S. Karbasian, (2007) IEEE
8. B. K. Bose, P. M. Szczesny, R. L. Steigerwald, Proceedings of the IEEE Industry Applications Society annual meeting, (Sept. 1984), pp. 852-859
9. C. R. Sullivan, M. J. Powers, Proceedings of the IEEE-PESC Power Electronics Specialists conference, (1993), pp. 574-580
10. C. Y. Won, D. H. Kim, S. C. Kim, W. S. Kim, and H. S. Kim, Proceedings of the IEEE Power Electronics Specialists conference, (1994), pp. 396403