

## A DC-DC Boost Converter with Extended Voltage Gain

Muhammad Zeeshan Malik<sup>1</sup>, Ajmal Farooq<sup>1</sup>, Amjad Ali<sup>1</sup>, Guozhu Chen<sup>1</sup>, Member, IEEE

<sup>1</sup> College of Electrical Engineering, Zhejiang University, Hangzhou, China

**Abstract.** In this paper a DC-DC boost converter with voltage extension cell is introduced to reduce losses and voltage stresses on circuit components. From theoretical analysis it has been analyzed that DC-DC boost converter coupled with extension cell enhances its voltage gain, which improve the life time of circuit components. Further to validate the proposed method, simulation has been performed in Matlab Simulink Software to compare the output voltage of boost converter with and without proposed method, result shows that the output voltage of proposed method is 35V as compare to simple boost converter 25 V. Voltage stress in case of basic boost converter is 25V while for boost converter with extension cell is 10 V.

### 1 Introduction

Renewable energy sources have diverted the intention of power producers and power electronics manufacturers to fulfill the electricity demands and mitigate energy crises. Different renewable energy sources (RES) such as wind, solar photovoltaic (PV) fuel cell (FC) are commonly used sources, but solar photovoltaic (PV) attracted the intention of research in recent years because of its abundant availability [1-3]. Solar PV produces fluctuated output voltage because of non-uniform solar irradiances. Therefore, different types of DC-DC or DC-AC converter are being used to get required and stable output. In [4] Interleaved boost converter with two phases is presented, in which advantages of interleaved over boost converter distributing input current because of its phases is discussed. This converter can be used in high power applications. The disadvantage of interleaved boost converter is that it is hard to control due to phase displacement. The quadratic boost converter is presented in [3]. This converter has two parts and each part work as a separate boost converter. Quadratic boost converter is capable for high voltage gain but the main drawback is division of energy in two parts, which causes high energy loss. A boost converter with two intermediate capacitors is discussed in [5-6], in which comparison of two converter topology with advantages of doubling the output voltage because of intermediate capacitor for high voltage application is explained. And in [7-8] the boost converter with winding cross coupled inductor (WCCIs) is presented and tapped inductor boost converter topology with the advantage of high voltage gain because of magnetic properties is proposed in [9-12].

In this article a boost converter with voltage extension cell is presented for high voltage gain. Circuit diagram of the proposed converter with extension cell is depicted in

figure-1. The proposed converter can achieve high voltage gain because of extension cell and the capacitor, which tends to reduce not only voltage stress on the switches but also increase the overall system efficiency as well improve the life of converter components because of low stress.  $L_s$  is the equivalent inductance of the wire and it is ignored in the steady state analyze.

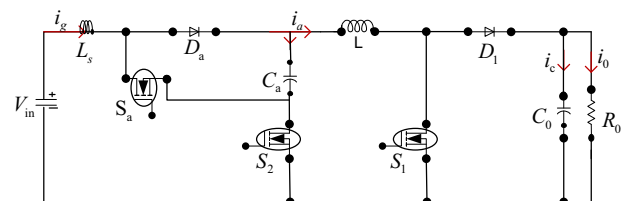

Figure 1. Boost converter with extension cell

### 2 Operating principle of the proposed converter:

Figure-2 shows the circuit diagram of boost converter with proposed extension cell module. It consists of diode ( $D_a$ ) and ( $D_1$ ) as rectifying diodes, ( $L$ ) is filtering inductor and  $S_a$ ,  $S_1$  and  $S_2$  are transistor switches, ( $R_o$ ) is resistor load and ( $V_o$ ) is output voltage.

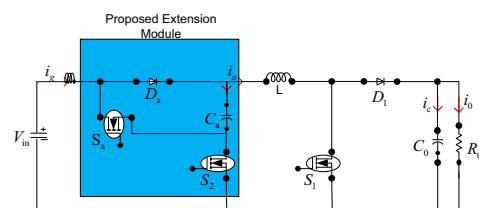

Figure 2. DC-DC Boost Converter with extended cell module

The proposed converter is operated with fixed switching frequency of 100 kHz and the switching period is  $T_s$ . Switches  $S_a, S_1$  and  $S_2$  turn ON and turn OFF with two PWM signals.  $S_2$  and  $S_1$  are operated at one PWM signal and the  $S_a$  is operated by 2<sup>nd</sup> PWM signal, which is the inverse of 1<sup>st</sup> PWM. The steady state wave forms of the proposed converter are depicted in figure-4.

There are two switching states with one switching period  $T_s$  as shown in figure-4 (a)&(b).

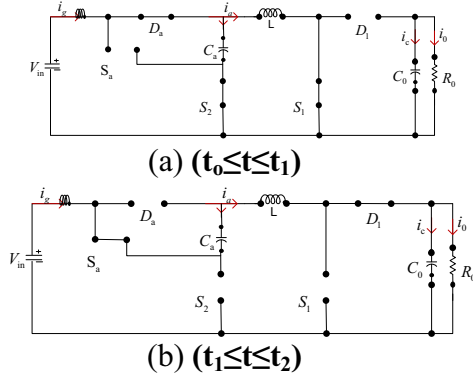

Figure 3. Operating mode of the proposed converter

### 2.1 State-I ( $t_0 \leq t \leq t_1$ )

The time of this state is from  $t_0=0$  to  $t_1=DT_s$  and the circuit diagram of proposed converter is shown in figure-3 (a) where diode  $D_a$ , switch  $S_1$  and switch  $S_2$  are ON, while switch  $S_a$  and diode  $D_1$  are turned OFF. At this stage  $D_a$  conducts and current divides in two parts. Partly it passes through inductor and switch  $S_1$  partly it charges capacitor  $C_a$  and passes through switch  $S_2$ .

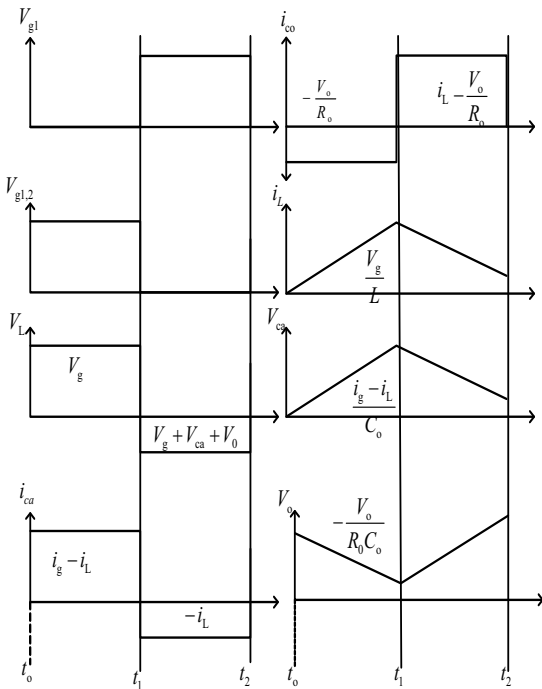

Figure-4. Steady state figure

### 2.2 State-II ( $t_1 \leq t \leq t_2$ )

The time of this state is from  $t_1=DT_s$  to  $t_2=T_s$  and the circuit diagram of proposed converter is shown in figure-3(b) where Diode  $D_a$ ,  $S_1$  and  $S_2$  are turned OFF. The switch  $S_a$  is ON and diode  $D_1$  conducts and partly current charges capacitor  $C_o$  and partly it passes through load.

### 2.3 Steady state analysis of the proposed converter

In stage-I we can see in figure-3(a). When the switch  $S_a$  and diode  $D_1$  are in OFF mode. That time switch  $S_1$  and  $S_2$  are ON. The state equation in stage-I are shown bellow.

$$V_L = V_{ca} = V_{in} \quad (1)$$

$$i_{ca} = i_g - i_L \quad (2)$$

$$i_{co} = -i_o = -\frac{V_o}{R_o} \quad (3)$$

At stage-II we can see in figure-3(b) when switches  $S_1$  and  $S_2$  are OFF and Switch  $S_a$  is ON the state equation in this stage are:

$$V_L = V_{in} + V_{ca} - V_o \quad (4)$$

$$i_{ca} = -i_L \quad (5)$$

$$i_{co} = i_L - i_o = i_L - \frac{V_o}{R_o} \quad (6)$$

### 3 DC conversion ratio

Using the principle of inductor volt second balance on inductors (L) gives the voltage conversion ratio of the proposed converter:

$$DV_{in} + (1 - D)(V_{in} + V_{ca} - V_o) = 0 \quad (7)$$

after solving the equation (7) we get:

$$V_o = \frac{V_{in}}{1 - D} + V_{in} \quad (8)$$

Again from inductor volt second balance of L we get:

$$DV_{ca} + (1 - D)(V_{in} + V_{ca} - V_o) = 0 \quad (9)$$

after solving the equation(9) we get:

$$V_o = \frac{V_{ca}}{1 - D} + V_{in} \quad (10)$$

From (8) & (10) we get

$$\frac{V_{ca}}{1 - D} + V_{in} = \frac{V_{ca}}{1 - D} + V_{in} \quad (11)$$

after solving equation(11) we get

$$V_{ca} = V_{in} \quad (12)$$

in equation (8) we know  $V_{ca}=V_g$  after put the  $V_{ca}$  value

$$V_o = \frac{V_{in}}{1-D} + V_{in} \quad (13)$$

From equation (13) we get voltage gain equation below:

$$M = \frac{V_o}{V_{in}} = \frac{2-D}{1-D} \quad (14)$$

### 3.1. Ripple voltage and ripple current of converter

In figure-3 of steady state, the peak to peak ripple current  $\Delta i$  equation drawn below:

$$\Delta i = \frac{DV_{in}T_s}{L} \quad (15)$$

In figure-3 peak to peak voltage  $\Delta v$  and ripple voltage given in below:

$$\Delta_{V0} = -\frac{V_o}{R_o C} DT_s \quad (16)$$

### 3.2 Voltage Stress of devices in proposed converter

Using the circuit diagram of proposed converter in state-I the voltage stress of switch Sa and diode  $D_a$  are:

$$V_{sa} = V_{ca} \quad (17)$$

$$V_{D1} = V_o \quad (18)$$

Similarly, from stage II, the voltage stress of diode  $D_a$ , switch S1, and S2 are:

$$V_{Da} = V_{ca} \quad (19)$$

$$V_{s2} = V_{in} \quad (20)$$

$$V_{s1} = V_o \quad (21)$$

## 4 Simulation results

To validate the performance of the proposed converter, simulations are done in Matlab Simulink software for both proposed and the traditional DC-DC boost converters according to parameters given in Table-1 and comparison between both the converters output results are shown in figure-5 (a)&(b) respectively.

**Table 1.** Parameters of proposed converter

Name of parameter	Symbol	Value
Output power	$P_o$	35W
Input Voltage	$V_s$	10 [V]
Output Voltage	$V_o$	35 [V]
Load Resistance	$R_L$	35 [ $\Omega$ ]
Frequency	$F_s$	100 [kHz]
Filter inductor/phase	$L$	1.2 [mH]
Intermediate capacitor	$C_{in}$	200[uF]
Output capacitor	$C_o$	60[uF]

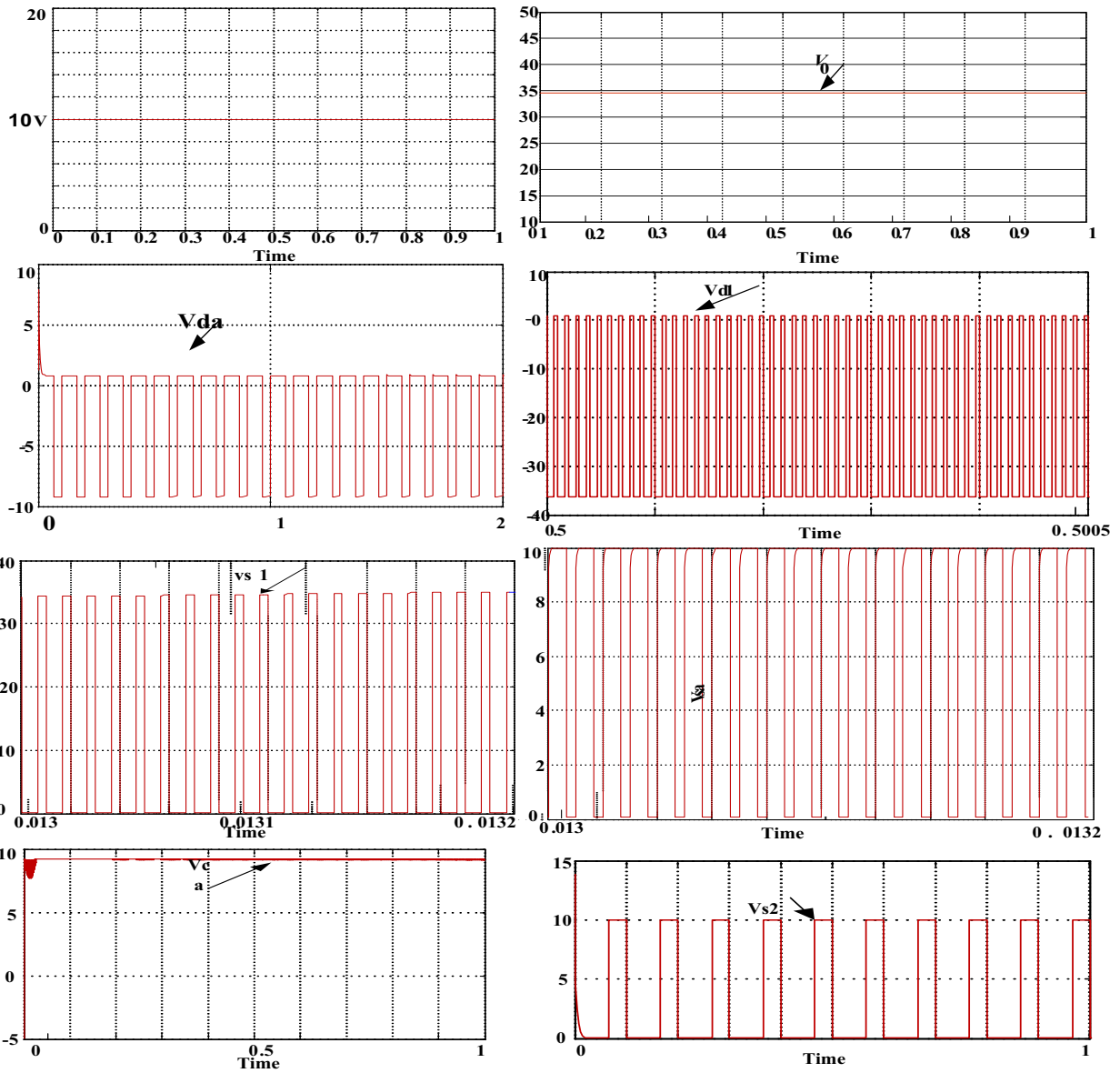

Figure-5(a). Simulation result of proposed converter

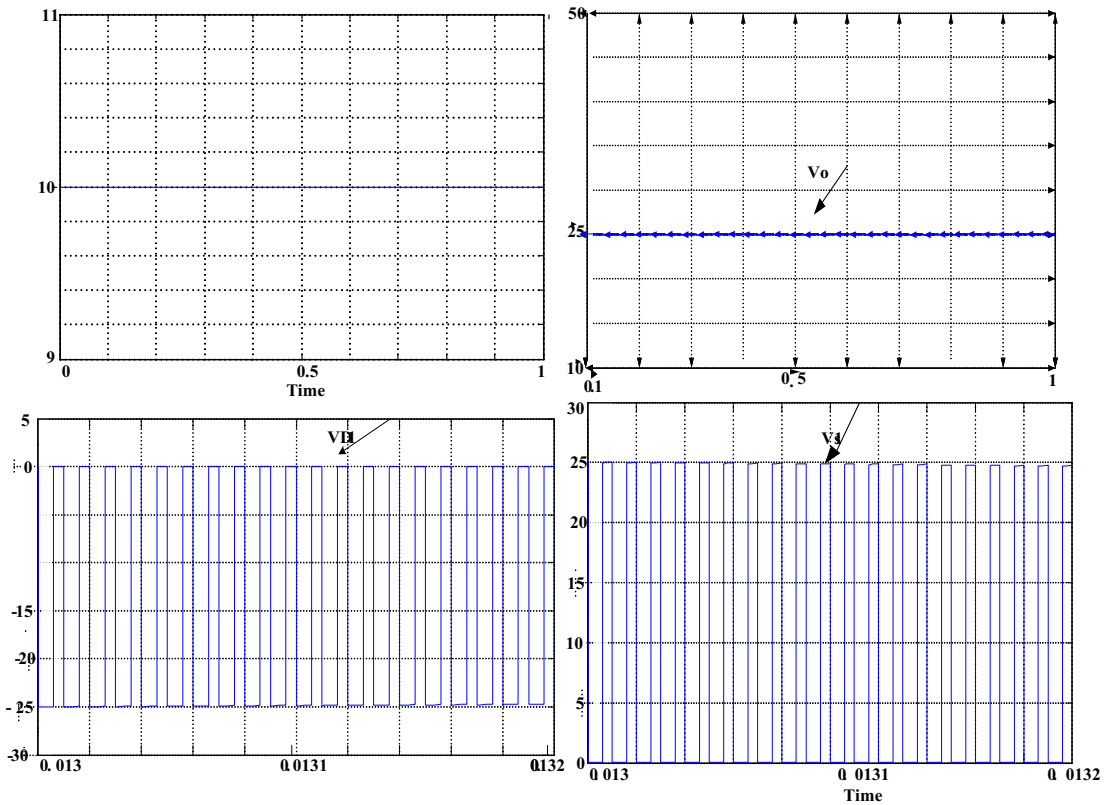

Figure-5(b). Simulation result of boost converter

In figure-5(a)&(b) simulation results of boost converter with voltage extension cell and simple boost converter are compared. It can be easily observed that input voltage for both converters is 10 volts while output voltage of boost converter with voltage extension cell is nearly 35 volts and that of simple boost converter is nearly 25V. The voltage stresses of switches in boost converter with extension cell is much lower, that is 10V, than that of simple boost converter which is 25V.

### 5 Conclusion

A new topology of boost converter with voltage extension cell is presented in this paper. The boost converter with voltage extension cell enhances output and reduces voltage stresses on switches and other losses which is clear from both simulations and theoretical results. It increases life time of circuit components due to lower voltage stresses. Boost converter with extension cell can be used in photovoltaic power generation and other low input voltage and high output voltage gain circuits.

### References

1. [http://www.erec.org/fileadmin/erec\\_docs/Documents/P.ublications/Renewable\\_Energy\\_Technology\\_Roadmap.pdf](http://www.erec.org/fileadmin/erec_docs/Documents/P.ublications/Renewable_Energy_Technology_Roadmap.pdf), Renewable Energy Technology Roadmap 20% by (2020) [Online]
2. M. Amirabadi, A. Balakrishnan, H. Toliyat, and W. Alexander, *IEEE Trans. Ind. Electron.* **61**, 281–291 (2014)
3. Soft-Switching AC-Link Three-Phase AC–AC Buck–Boost Converter, *IEEE Trans. Ind. Elec.* **62**, (2015)
4. A Performance Comparison of Interleaved Boost Converter and Conventional Boost Converter for Renewable Energy Application, *Proceedings of 2013 International Conference on Green High Performance Computing*, March 14-15, (2013), India
5. X. et al. Huang, *Applied Power Electronics Conference and Exposition, APEC*, (2003)
6. M. G. et al. Ortiz-Lopez, "Current-Mode Control for a Quadratic Boost Converter with a Single Switch," *IEEE Power Electronics Specialists Conference, PESC*, (2007)
7. H. Nomura, K. Fujiwara, and M. Yoshida, *IEEE Power Electronics Specialists Conference*, (2006)
8. C. Yoon, J. Kim and S. Choi, *IEEE Trans. Power Electron.* **26**, 381-388 (2011)
9. Z. Yi, W. Li, Y. Deng and X. He, *IEEE Trans. Power Electron.* **26**, 541-550 (2011)
10. H. Z. Yang, J. Liu, "Research on Maximum Power Point Tracking Control Based on the Low Power Photovoltaic Grid-connected Inverter,"
11. *IEEE Power Electronics and Motion Control Conference*, (2009), pp. 2165-2169
12. Y. R. De Novaes, A. Rufer, I. Barbi, "A New Quadratic, Three-Level, DC/DC Converter Suitable for Fuel Cell Application," *IEEE Power Conversion Conf.*, (2007), pp. 601-607